

CATALYST



Made of Stars

Eve Frudakis
2021 Design Development Package

:: EXECUTIVE SUMMARY

::THESIS STATEMENT

Mindfulness meditation practice heightens awareness in the present moment, **deep sustained engagement, and focus**, which are qualities that go ignored in today's multitasking, fast-moving world. Human perception in response to specific forms of **lighting** in the designed environment **influences automatic physiological reactions affecting audiences' mental and physical states. Lighting effects can be employed as a gestalt in driving the design of an environment that activates mindfulness, creating enhanced well-being, and value in visitor experience in the form of positive inward and outward reflection.**

Eve Frudakis <i>Exhibition and Experience Design</i>	Fashion Institute of Technology <i>School of Graduate Studies</i> 272 West 27th St. New York, NY 10011	Project: 	Client: 	DISCLAIMER <small>This is an unpublished and proprietary work simultaneously protected under copyright, trade secret, and like laws of the United States and other countries. All rights reserved. These materials may not be reproduced, displayed, distributed, nor may be the information therein be used or disclosed in whole or in part, without the express written permission of Eve Frudakis.</small>	Key Plan:	Title:	Scale: Drawn by: <i>Eve Frudakis</i> Date: <i>11.03.2021</i>	EX 100 Drawing NO.
EXHIBITION DOCUMENTATION								

::CLIENT DESCRIPTION



The client for this exhibition is **the American Museum Of Natural history**, established in 1869.

Their mission is to “discover, interpret, and disseminate—through scientific research and education—knowledge about human cultures, the natural world, and the universe.” They aim to inspire future generations.

As noted in their annual report, the museum “promotes a broader understanding of the natural world of generations to come!”

Within the Hayden planetarium in the museum in the Rose Center for Earth and Space lyes a permanent exhibition dedicated to the powers of 10.



Eve Frudakis <i>Exhibition and Experience Design</i>	Fashion Institute of Technology <i>School of Graduate Studies</i> 272 West 27th St. New York, NY 10011	Project: 	Client: 	DISCLAIMER This is an unpublished and proprietary work simultaneously protected under copyright, trade secret, and like laws of the United States and other countries. All rights reserved. These materials may not be reproduced, displayed, distributed, nor may be the information therein be used or disclosed in whole or in part, without the express written permission of Eve Frudakis.	Key Plan:	Title:	Scale: Drawn by: <i>Eve Frudakis</i> Date: <i>11.03.2021</i>	EX 102 Drawing NO.
EXHIBITION DOCUMENTATION								

::SUBJECT: POWERS OF 10

“Powers of 10” is essential because not only does it recognize what we have and the things

we all know and love, but it also celebrates the unknown. It shows our human connection with nature and the mystery of the cosmos. That is— no matter how big or small the world, there is a unifying factor. Whether you are looking through a microscope or a telescope, these worlds are not as far apart as they seem.

Life is created through six essential elements:



carbon, hydrogen, nitrogen, oxygen, phosphorus, and sulfur.

Everyone and every living thing on our planet are united because they contain the same ingredients as the stars.

This understanding of the natural world is essential for society because it **enhances well-being** and enables people to form deeper connections and compassion for the environment that surrounds them. Having a solid well-adapted sense of our health and overall happiness is essential for growth, energy, and achievement, much like how CHNOPS elements are necessary for life and energizing the planetary and atomic worlds surrounding us.

This exhibition aims to encourage and inspire positive moments of mindfulness, inward and outward reflection for the visitor in a world where so much is happening literally in Time Square and metaphorically amidst a pandemic and politically charged world.

In 1968 *“The powers of 10”* film was released by Ray and Charles Eames. Since the debut of the short film, it has been recognized as an American cultural icon and an essential tool for teaching and understanding the importance of scale. “The Powers of 10” is a magnificent wonder which combines a gamut of sciences into one beautiful visual film/book illustrating the macrocosm and microcosm of the universe as we know it.

Eve Frudakis <i>Exhibition and Experience Design</i>	Fashion Institute of Technology <i>School of Graduate Studies</i> 272 West 27th St. New York, NY 10011	Project: 	Client: 	DISCLAIMER <small>This is an unpublished and proprietary work simultaneously protected under copyright, trade secret, and like laws of the United States and other countries. All rights reserved. These materials may not be reproduced, displayed, distributed, nor may be the information therein be used or disclosed in whole or in part, without the express written permission of Eve Frudakis.</small>	Key Plan: 	Title: 	Scale: Drawn by: <i>Eve Frudakis</i> Date: 11.03.2021	EX 103 Drawing NO.
EXHIBITION DOCUMENTATION								

::AUDIENCE DESCRIPTION

Primary: 18-25

Secondary: Nearby office workers

Tertiary: Tourists & first-time city-goers in the area



Being that the AMNH takes pride in promoting **understanding of the natural world for future generations this exhibition aims to target young adults in hopes that they find more of an interest in museums.**

Generation Z's cohort was born between 1996 and the early-mid 2000s.

The exhibition focuses on all audience type but primarily streakers and strollers commuting through the space.

More about Gen Z

- First digital Natives.
- Referred to by some as the “loneliest generation,” It is said they face many mental health challenges due to not only the turbulent state of the world but many hours online can lead to fostered feelings of isolation and depression. More time spent on smartphones less time cultivating meaningful relationships.
- Politically progressive. As political activism among Gen Z has increased, many Gen Z-ers have internalized the unrest surrounding issues like gun control, police brutality, and climate change leading to increased levels of stress.
- Face an uncertain Future.
- Members of Gen Z are more concerned about the cost of education

Eve Frudakis <i>Exhibition and Experience Design</i>	Fashion Institute of Technology <i>School of Graduate Studies</i> 272 West 27th St. New York, NY 10011	Project: 	Client: 	DISCLAIMER This is an unpublished and proprietary work simultaneously protected under copyright, trade secret, and like laws of the United States and other countries. All rights reserved. These materials may not be reproduced, displayed, distributed, nor may be the information therein be used or disclosed in whole or in part, without the express written permission of Eve Frudakis.	Key Plan:	Title:	Scale: Drawn by: <i>Eve Frudakis</i> Date: 11.03.2021	EX 104 Drawing NO.
EXHIBITION DOCUMENTATION								

::VENUE DESCRIPTION

The interstitial spaces are calm amongst the chaos of Times Square. Through site visits and observation, there are few people pass through. People who utilize the spaces tend to be more familiar with the area and know where they are. People appear to be on their way to work or escaping the hectic crowds. Most people use the spaces to pass through quickly and efficiently, business varies depending on the day. Some people use the areas for quiet morning commutes, and others find refuge in public seating in Nederlander alley at lunchtime.

Each interstitial space will have a different sponsor corresponding to the measurement/power the environment is based on.

All sponsors are preexisting sponsors of AMNH.

“What we can see.” is Located at Shubert Alley btw 44th & 45th st. New York NY 10036

Sponsored by: **Google inc.**

Mission is to organize the world’s information and make it universally accessible and useful.

“What is a fractal?” Is located at the Minskoof Theatre, 200W 45th st. New York, NY 10036

Sponsored by: **Pfizer.**

Mission is to Innovate every day to make the world a healthier place. Paired with **Sony Corporation of America.**

Missions: to fill the world with emotion, through the power of creativity and technology, and to nurture innovation to enrich and improve people’s lives.

“Atomic mayhem.” is located at The Marriott Marquis Parking Lot 1535 Broadway



Sponsored by: **IBM Corporation.**

Mission is to lead in the creation, development, and manufacture of the industry’s most advanced information technologies, including computer systems, software, networking systems, storage devices, and microelectronics.

“Cosmic Scale” Located in James M. Nederlander Alley 46th st. Side of Marriott Marquis btw Broadway & 8th Ave. 100

Sponsored by **Sony Corporation of America.**

Mission: is to fill the world with emotion, through the power of creativity and technology, and to nurture innovation to enrich and improve people’s lives.

<p>Eve Frudakis Exhibition and Experience Design</p>	<p>Fashion Institute of Technology School of Graduate Studies 272 West 27th St. New York, NY 10011</p>	<p>Project:</p> 	<p>Client:</p> 	<p>DISCLAIMER This is an unpublished and proprietary work simultaneously protected under copyright, trade secret, and like laws of the United States and other countries. All rights reserved. These materials may not be reproduced, displayed, distributed, nor may be the information therein be used or disclosed in whole or in part, without the express written permission of Eve Frudakis.</p>	<p>Key Plan:</p>	<p>Title:</p>	<p>Scale:</p> <p>Drawn by: <i>Eve Frudakis</i></p> <p>Date: 11.03.2021</p>	<p>EX 105</p> <p>Drawing NO.</p>
<p>EXHIBITION DOCUMENTATION</p>								

::SITE MAP

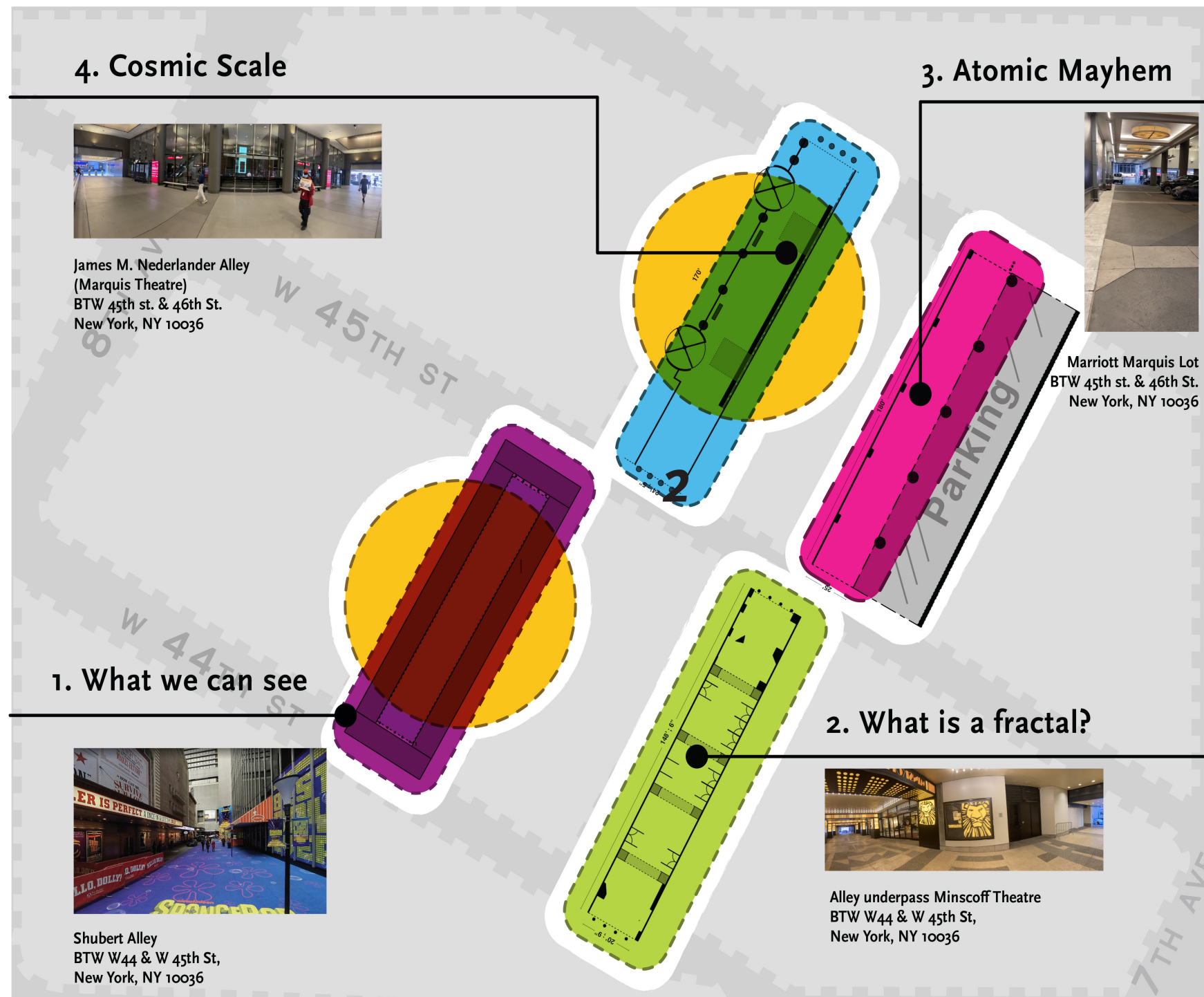

Eve Frudakis
 Exhibition and Experience Design
 EXHIBITION DOCUMENTATION

Fashion Institute of Technology
 School of Graduate Studies
 272 West 27th St.
 New York, NY 10011

Project:
CATALYST
 Made of Stars

Client:
 AMERICAN MUSEUM
 OF NATURAL HISTORY

DISCLAIMER
 This is an unpublished and proprietary work simultaneously protected under copyright, trade secret, and like laws of the United States and other countries. All rights reserved. These materials may not be reproduced, displayed, distributed, nor may be the information therein be used or disclosed in whole or in part, without the express written permission of Eve Frudakis.

Key Plan: Title:

Scale:
 Drawn by: *Eve Frudakis*
 Date: 11.03.2021

EX 106
 Drawing NO.

::EXHIBIT GOALS

Project Goals:



- Reach and **engage new audiences**, primarily generation Z (young adults).
- Encourage connections, **well being**, and exploration in visitors to gain a deeper understanding of the natural world around them / us.
- **Spark imagination and curiosity through discovery.**

Experience Goals:

- This Exhibition will have **moments of stillness** for viewers to have **inward reflection as well as moments of constant movement.**
- The audience will gain a **deeper understanding of scale** and recognize the vastness of our universe as well as issues we are faced at hand.
- The audience will **experience meaning making.**

Educational Goals:

- Visitors will learn about how we are all **connected.**
- Visitors will learn about the **size and scale** of things within our universe and the world.
- Visitors will learn about **powers of 10** are used as a unit to measure the super big and the super small.
- Visitors will learn about what the human eye is capable of seeing.

<p>Eve Frudakis Exhibition and Experience Design</p>	<p>Fashion Institute of Technology School of Graduate Studies 272 West 27th St. New York, NY 10011</p>	<p>Project:</p> 	<p>Client:</p> 	<p>DISCLAIMER This is an unpublished and proprietary work simultaneously protected under copyright, trade secret, and like laws of the United States and other countries. All rights reserved. These materials may not be reproduced, displayed, distributed, nor may be the information therein be used or disclosed in whole or in part, without the express written permission of Eve Frudakis.</p>	<p>Key Plan:</p>	<p>Title:</p>	<p>Scale:</p> <p>Drawn by: <i>Eve Frudakis</i></p> <p>Date: 11.03.2021</p>	<p>EX 107</p> <p>Drawing NO.</p>
<p>EXHIBITION DOCUMENTATION</p>								

::CONCEPT DIAGRAM

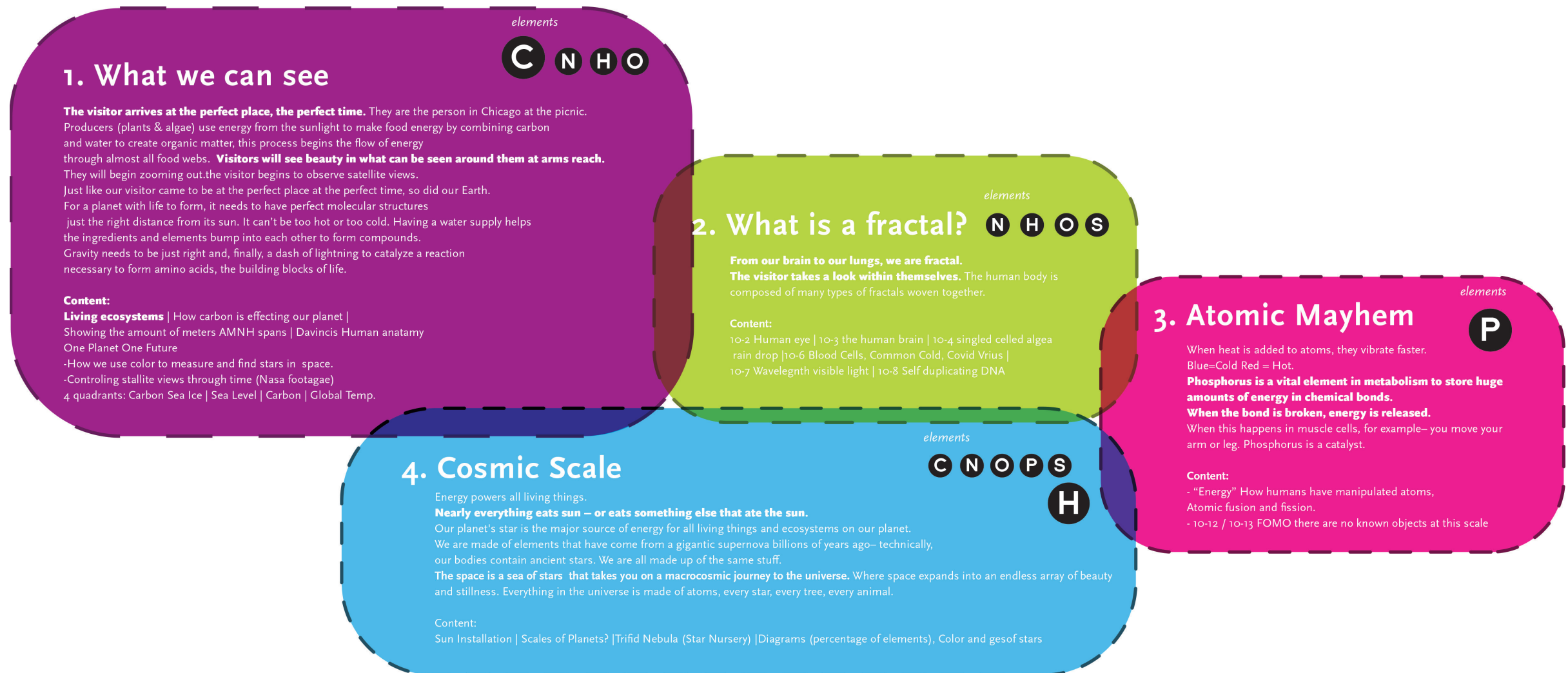

Eve Frudakis <i>Exhibition and Experience Design</i>	Fashion Institute of Technology <i>School of Graduate Studies</i> 272 West 27th St. New York, NY 10011	Project: 	Client: 	DISCLAIMER This is an unpublished and proprietary work simultaneously protected under copyright, trade secret, and like laws of the United States and other countries. All rights reserved. These materials may not be reproduced, displayed, distributed, nor may be the information therein be used or disclosed in whole or in part, without the express written permission of Eve Frudakis.	Key Plan: 	Title: 	Scale: 	EX 108 Drawing NO.
							Drawn by: <i>Eve Frudakis</i> Date: 11.03.2021	
EXHIBITION DOCUMENTATION								

::FLOOR PLAN

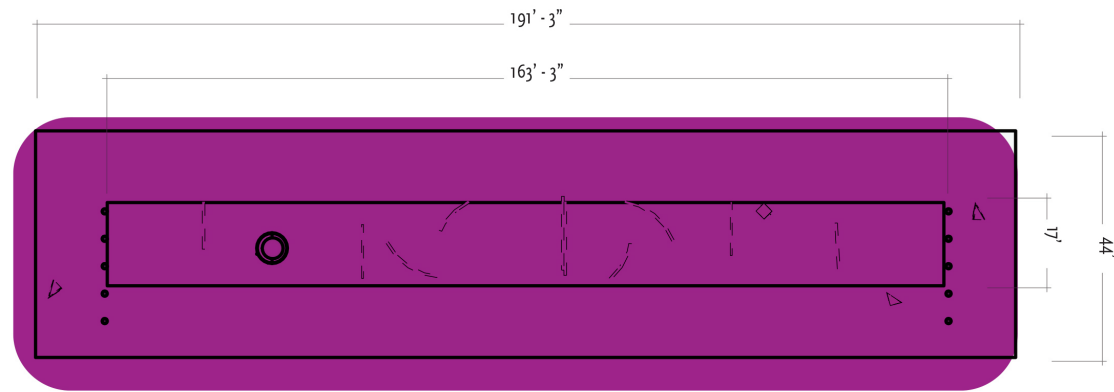

1 :: What we can see
 ::Location:: Shubert Alley btw 44th & 45th st. New York NY 10036
 001 scale: N/A

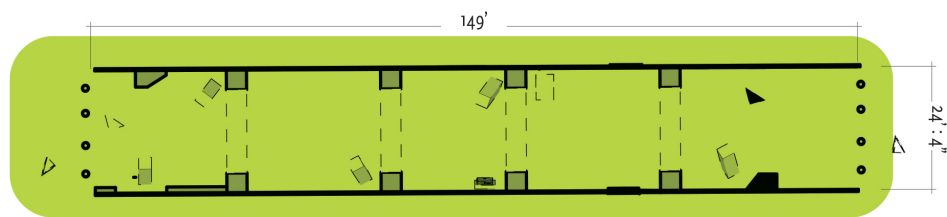



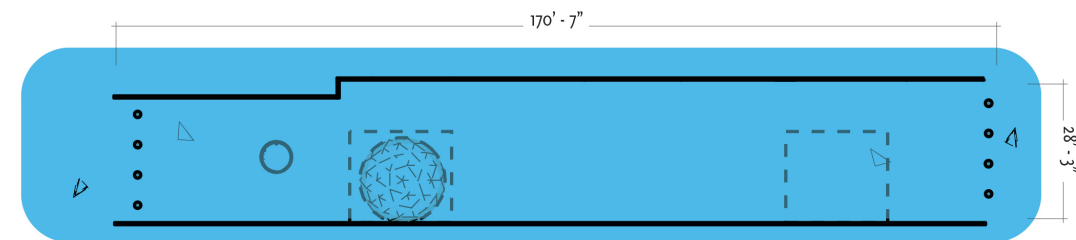

2 :: What is a Fractal?
 ::Location:: 200 W 45th St, New York, NY 10036
 001 scale: N/A

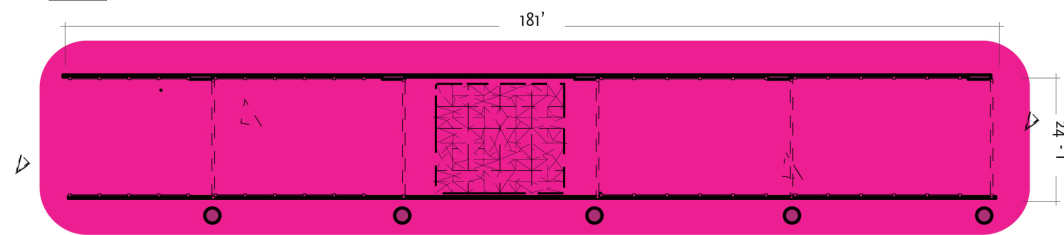



4 :: Cosmic Scale
 ::Location:: James M. Nederlander Alley 46th st. Side of Marriott Marquis btw Broadway & 8th Ave. 10036
 001 scale: N/A







3 :: Atomic Mayhem: Collectively Connected
 ::Location:: The Marriott Marquis Parking Lot 1535 Broadway
 001 scale: N/A

	01 What we can see	CONTENT At arms reach Proof is in the pudding
	02 What is a fractal?	Microcosm systems of chaos
	03 Atomic Mayhem	Motion Potion
	03 Cosmic Scale	Sea of stars

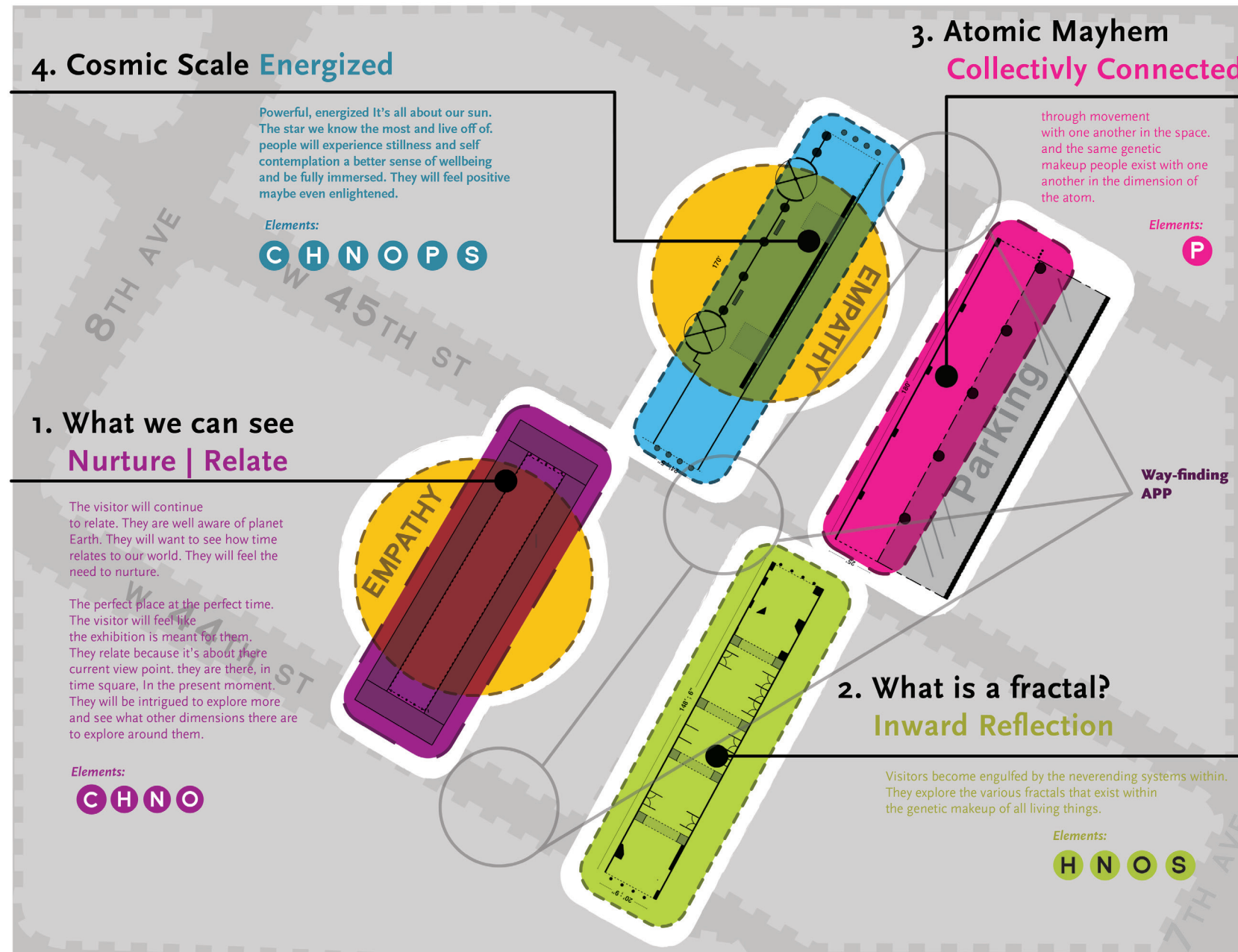
Eve Frudakis <i>Exhibition and Experience Design</i>	Fashion Institute of Technology <i>School of Graduate Studies</i> 272 West 27th St. New York, NY 10011	Project: 	Client: 	DISCLAIMER This is an unpublished and proprietary work simultaneously protected under copyright, trade secret, and like laws of the United States and other countries. All rights reserved. These materials may not be reproduced, displayed, distributed, nor may be the information therein be used or disclosed in whole or in part, without the express written permission of Eve Frudakis.	Key Plan: 	Title: 	Scale: 	EX 109 Drawing NO.
							EXHIBITION DOCUMENTATION	

::EMOTIONAL JOURNEY MAP







Eve Frudakis Exhibition and Experience Design	Fashion Institute of Technology School of Graduate Studies 272 West 27th St. New York, NY 10011	Project: 	Client: 	DISCLAIMER This is an unpublished and proprietary work simultaneously protected under copyright, trade secret, and like laws of the United States and other countries. All rights reserved. These materials may not be reproduced, displayed, distributed, nor may be the information therein be used or disclosed in whole or in part, without the express written permission of Eve Frudakis.	Key Plan:	Title:	Scale: Drawn by: <i>Eve Frudakis</i> Date: 11.03.2021	 EX 110 Drawing NO.
---	---	---	--	---	-----------	--------	---	--

::INTRODUCTION

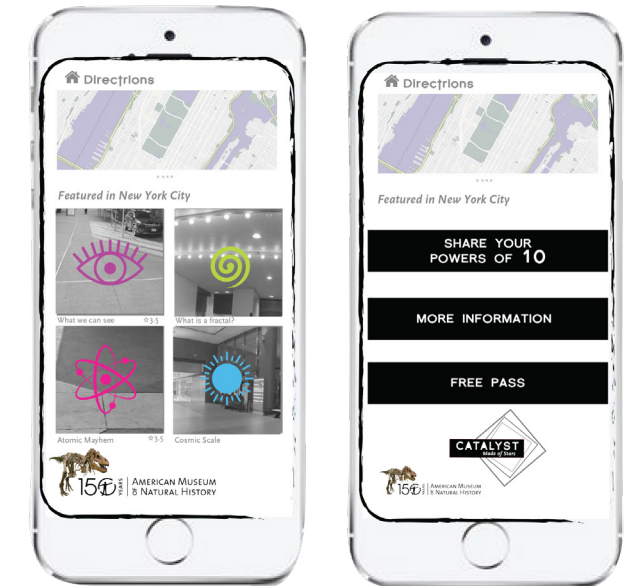
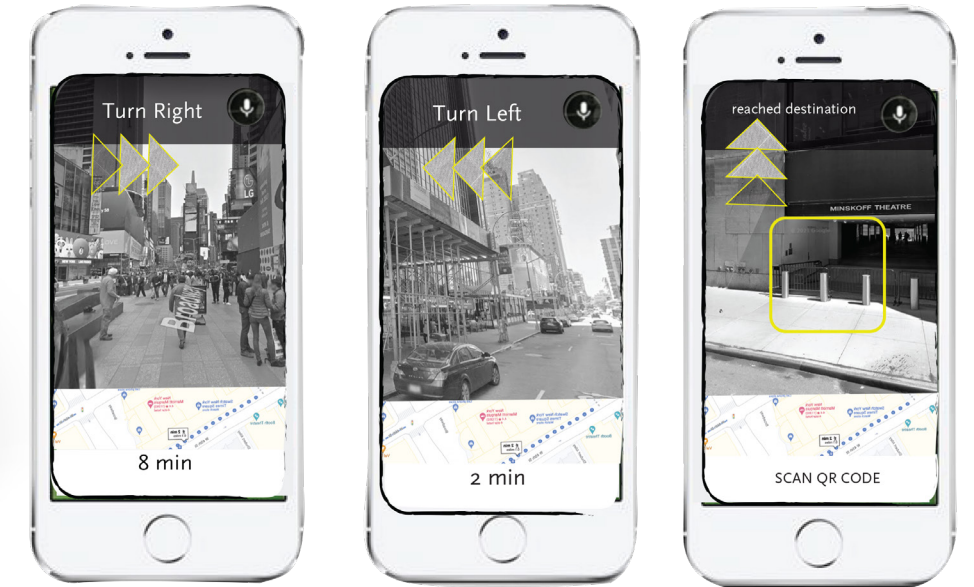

Proof of concept

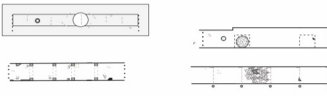

<p>Eve Frudakis Exhibition and Experience Design</p>	<p>Fashion Institute of Technology School of Graduate Studies 272 West 27th St. New York, NY 10011</p>	<p>Project:</p> 	<p>Client:</p> 	<p>DISCLAIMER This is an unpublished and proprietary work simultaneously protected under copyright, trade secret, and like laws of the United States and other countries. All rights reserved. These materials may not be reproduced, displayed, distributed, nor may be the information therein be used or disclosed in whole or in part, without the express written permission of Eve Frudakis.</p>	<p>Key Plan:</p> 	<p>Title:</p>	<p>Scale:</p> <p>Drawn by: <i>Eve Frudakis</i> Date: 11.03.2021</p>	 <p>EX 111</p> <p>Drawing NO.</p>
---	---	---	--	---	--	---------------	---	---

:::AREA 01 RENDER

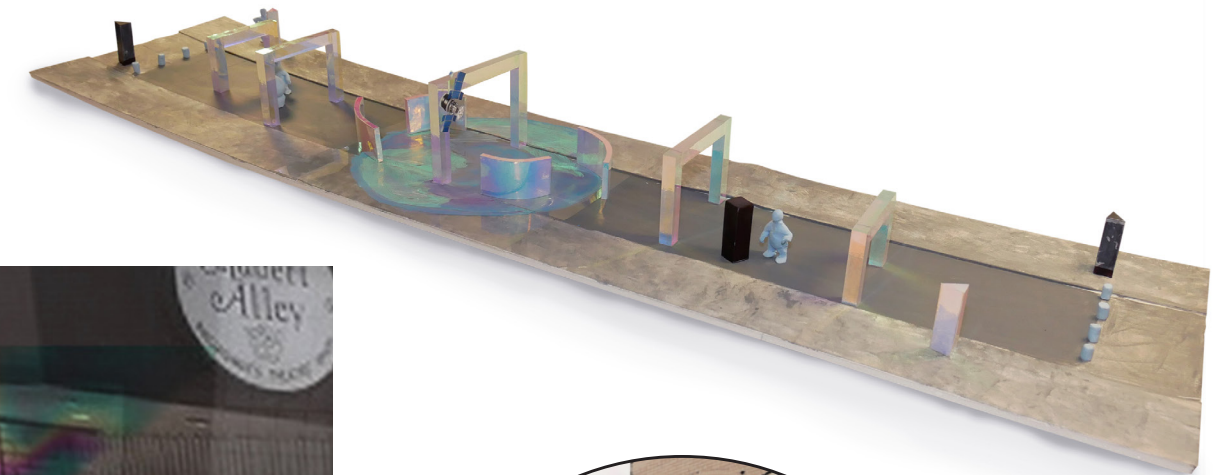





Above: 01A model

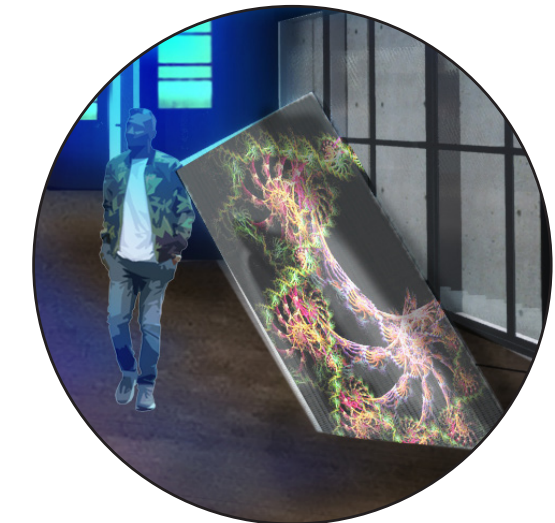

<p>Eve Frudakis Exhibition and Experience Design</p>	<p>Fashion Institute of Technology School of Graduate Studies 272 West 27th St. New York, NY 10011</p>	<p>Project:</p>  <p>CATALYST Made of Stars</p>	<p>Client:</p>  <p>AMERICAN MUSEUM & NATURAL HISTORY</p>	<p>DISCLAIMER This is an unpublished and proprietary work simultaneously protected under copyright, trade secret, and like laws of the United States and other countries. All rights reserved. These materials may not be reproduced, displayed, distributed, nor may be the information therein be used or disclosed in whole or in part, without the express written permission of Eve Frudakis.</p>	<p>Key Plan:</p>  	<p>Title: <i>What we can see</i></p>	<p>Scale: N/A</p>	 <p>EX 112</p>
<p>EXHIBITION DOCUMENTATION</p>						<p>Drawn by: <i>Eve Frudakis</i></p>	<p>Date: 11.03.2021</p>	<p>Drawing NO.</p>

::AREA 02 RENDER

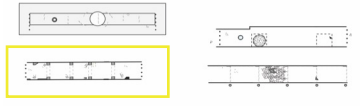

<p>Eve Frudakis Exhibition and Experience Design</p>	<p>Fashion Institute of Technology School of Graduate Studies 272 West 27th St. New York, NY 10011</p>	<p>Project:</p> 	<p>Client:</p> 	<p>DISCLAIMER This is an unpublished and proprietary work simultaneously protected under copyright, trade secret, and like laws of the United States and other countries. All rights reserved. These materials may not be reproduced, displayed, distributed, nor may be the information therein be used or disclosed in whole or in part, without the express written permission of Eve Frudakis.</p>	<p>Key Plan:</p> 	<p>Title: <i>What is a fractal?</i></p>	<p>Scale: N/A</p> <p>Drawn by: <i>Eve Frudakis</i></p> <p>Date: 11.03.2021</p>	 <p>EX 113</p> <p>Drawing NO.</p>
---	---	---	--	---	--	---	--	---

:::AREA 03 RENDER

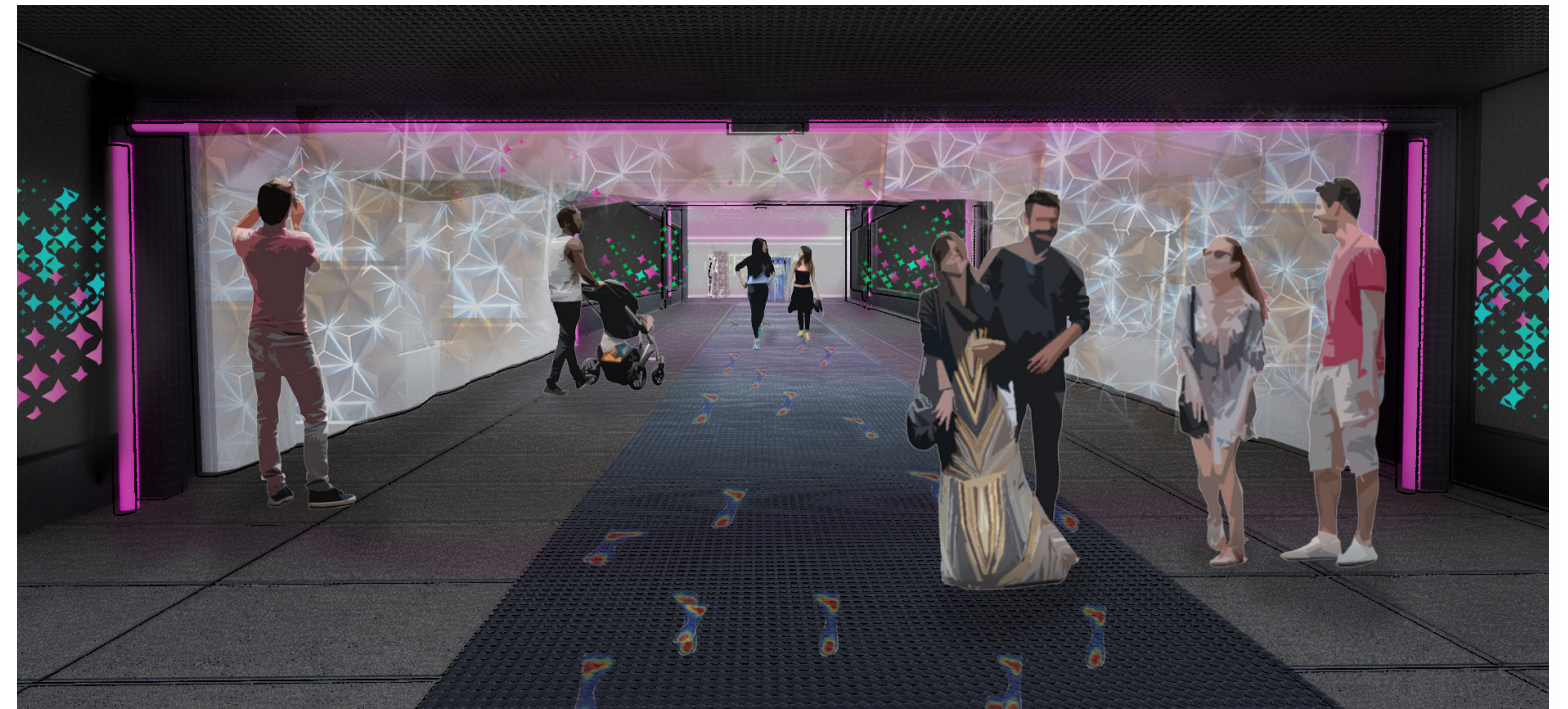

Eve Frudakis
Exhibition and Experience Design
EXHIBITION DOCUMENTATION

Fashion Institute of Technology
School of Graduate Studies
272 West 27th St.
New York, NY 10011

Project:
CATALYST
Made of Stars

Client:
AMERICAN MUSEUM
& NATURAL HISTORY

DISCLAIMER
This is an unpublished and proprietary work simultaneously protected under copyright, trade secret, and like laws of the United States and other countries. All rights reserved. These materials may not be reproduced, displayed, distributed, nor may be the information therein be used or disclosed in whole or in part, without the express written permission of Eve Frudakis.

Key Plan:

Title:
Atomic Mayhem

Scale:
N/A
Drawn by: *Eve Frudakis*
Date: 11.03.2021

EX 114
Drawing NO.

:::AREA 04 RENDER



Eve Frudakis
Exhibition and Experience Design

Fashion Institute of Technology
School of Graduate Studies
272 West 27th St.
New York, NY 10011

Project:



Client:



DISCLAIMER

This is an unpublished and proprietary work simultaneously protected under copyright, trade secret, and like laws of the United States and other countries. All rights reserved. These materials may not be reproduced, displayed, distributed, nor may be the information therein be used or disclosed in whole or in part, without the express written permission of Eve Frudakis.

Key Plan:

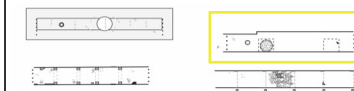

Title:
Cosmic View

Scale:
N/A

Drawn by: *Eve Frudakis*

Date: 11.03.2021





EX 115

Drawing NO.

:: SCHEDULES AND LISTS



:: Graphic Location Plan

:: Area	GR. Type	Description
What We Can See		
00A.01.GR01	A	Infinity mirror triangular column
00A.01.GR02	B	Aluminum triangular mount w/ type
00A.02.GR01	A	Infinity mirror triangular column
00A.02.GR02	B	Aluminum triangular mount w/ type
01A.03.GR01	C	Area intro triangular column covered w/ dichroic film placed extruded type and vinyl adhered graphic
01A.03.GR02	D	Clear acrylic panels w/ printed information
01A.04.GR01	C	Area intro triangular column covered w/ dichroic film placed extruded type and vinyl adhered graphic
01A.04.GR02	D	Clear acrylic panels w/ printed information
01A.03.GR01	F	“Look, see and here” activity box
01A.04.GR01	H	Display “Climate time machine: Sea level” sensor screen
01A.05.GR01	H	Display “Climate time machine: Sea Ice” sensor screen
01A.06.GR01	H	Display “Climate time machine: Global Temperature” sensor screen
01A.07.GR01	H	Display “Climate time machine: Carbon Dioxide” sensor screen
01A.01.GR01	E	Floor paint- Earth satalite view
01A.01.GR01	F	Diecut vinyl on ply- Satellite
01A.01.GR01	F	Truss covered dichroic film powers of 10 measurement frames
What is a Fractal?		
00A.01.GR01	A	Infinity mirror triangular column
00A.01.GR02	B	Aluminum triangular mount w/ type
00A.02.GR01	A	Infinity mirror triangular column
00A.02.GR02	B	Aluminum triangular mount w/ type
02A.03.GR01	C	Area intro triangular column covered w/ dichroic film placed extruded type and vinyl adhered graphic
02A.03.GR02	D	Clear acrylic panels w/ printed information
02A.04.GR01	C	Area intro triangular column covered w/ dichroic film placed extruded type and vinyl adhered graphic
02A.04.GR02	D	Clear acrylic panels w/ printed information
02A.05.GR01	H	“Fractal Labs” activity
02A.06.GR01	H	“within our blood stream” activity
02A.07.GR01	I	Powers of 10 measurement
02A.08.AV01	G	Media Cube 1
02A.09.AV02	G	Media Cube 2
02A.10.AV03	G	Media Cube 3
02A.11.AV04	G	Media Cube 4

Eve Frudakis <i>Exhibition and Experience Design</i>	Fashion Institute of Technology <i>School of Graduate Studies</i> 272 West 27th St. New York, NY 10011	Project: 	Client: 	DISCLAIMER This is an unpublished and proprietary work simultaneously protected under copyright, trade secret, and like laws of the United States and other countries. All rights reserved. These materials may not be reproduced, displayed, distributed, nor may be the information therein be used or disclosed in whole or in part, without the express written permission of Eve Frudakis.	Key Plan:	Title: <i>Drawing List</i>	Scale:	EX 200 Drawing NO.
							Drawn by: <i>Eve Frudakis</i> Date: <i>11.03.2021</i>	



:: Graphic Location Plan

:: Area	GR. Type	Description
Atomic Mayhem		
00A.01.GR01	A	Infinity mirror triangular column
00A.01.GR02	B	Aluminum triangular mount w/ type
00A.02.GR01	A	Infinity mirror triangular column
00A.02.GR02	B	Aluminum triangular mount w/ type
03A.03.GR01	C	Area intro triangular column covered w/ dichroic film placed extruded type and vinyl adhered graphic
03A.03.GR02	D	Clear acrylic panels w/ printed information
03A.04.GR01	C	Area intro triangular column covered w/ dichroic film placed extruded type and vinyl adhered graphic
03A.04.GR02	D	Clear acrylic panels w/ printed information
03A.04.GR01	D	Label of the nucleus
03A.04.AV01	G	Interactive wall screen 1
03A.04.AV02	G	Interactive wall screen 2
03A.04.AV03	G	Pressure sensitive flooring
03A.05.AV04	G	Projection mapping on nucleus
03A.05.GR01	F	Origami center nucleus
03A.01.GR05	G	Powers of 10 measurement frames (Lighting)
Cosmic Scale		
00A.01.GR01	A	Infinity mirror triangular column
00A.01.GR02	B	Aluminum triangular mount w/ type
00A.02.GR01	A	Infinity mirror triangular column
00A.02.GR02	B	Aluminum triangular mount w/ type
04A.03.GR01	C	Area intro triangular column covered w/ dichroic film placed extruded type and vinyl adhered graphic
04A.03.GR02	D	Clear acrylic panels w/ printed information
04A.04.GR01	C	Area intro triangular column covered w/ dichroic film placed extruded type and vinyl adhered graphic
04A.04.GR02	D	Clear acrylic panels w/ printed information
04A.05.GR01	F	Trifid nebula railing
04A.06.AV01	G	The sun
04A.06.AV02	G	Stars everywhere lighting
04A.03.GR02	F	Space mural painted on wall A (to be reflected w/ mirror on opposite side)

Eve Frudakis <i>Exhibition and Experience Design</i>	Fashion Institute of Technology <i>School of Graduate Studies</i> 272 West 27th St. New York, NY 10011	Project: 	Client: 	DISCLAIMER This is an unpublished and proprietary work simultaneously protected under copyright, trade secret, and like laws of the United States and other countries. All rights reserved. These materials may not be reproduced, displayed, distributed, nor may be the information therein be used or disclosed in whole or in part, without the express written permission of Eve Frudakis.	Key Plan:	Title: <i>Graphic Location Plan</i>	Scale:	EX 201 Drawing NO.
							Drawn by: <i>Eve Frudakis</i>	
EXHIBITION DOCUMENTATION								



:: Specification List

:: Type	Description
A	Fabricated Infinity mirror triangular column: (x2) 3/4" 2way mirror + (x1) 3/4" mirror w/ backer + 3/4" thick dimensional acrylic type painted black
B	1/4" think aluminum triangle mounted to triangular exhibition column column with 1/32" debossed type
C	Direct print on dichroic film, film applied to triangular exhibition column, with 1/2" thick dimensional acrylic type painted black, mounted with blind fasteners to triangular exhibition column
D	1/2" clear acrylic direct print panels mounted with blind fasteners to triangular exhibition column
E	Exterior grade floor graphic mounted to pavement
F	Direct print to fabric, hanging via cables
G	Clear acrylic displays (wrapped in dichroic film with screen 55" XE4F-M Series High Brightness Outdoor Displays casing with Adafruit motion control sensor
H	Stackable interactive wall screens to create wall interactive 15'x8' Planar TVFo.9 stackable by Planar with Adafruit motion control sensor
I	Pressure sensitive flooring mat, fabricator to advise





<p>Eve Frudakis Exhibition and Experience Design</p> <hr/> <p>EXHIBITION DOCUMENTATION</p>	<p>Fashion Institute of Technology School of Graduate Studies 272 West 27th St. New York, NY 10011</p>	<p>Project:</p> 	<p>Client:</p> 	<p>DISCLAIMER This is an unpublished and proprietary work simultaneously protected under copyright, trade secret, and like laws of the United States and other countries. All rights reserved. These materials may not be reproduced, displayed, distributed, nor may be the information therein be used or disclosed in whole or in part, without the express written permission of Eve Frudakis.</p>	<p>Key Plan:</p>	<p>Title: <i>Graphic Location Plan</i></p>	<p>Scale:</p> <hr/> <p>Drawn by: <i>Eve Frudakis</i></p> <hr/> <p>Date: <i>11.03.2021</i></p>	<p>EX 202</p> <hr/> <p>Drawing NO.</p>
--	---	---	--	---	------------------	--	---	---



:: Finish Schedule

MATERIAL	SYMBOL	EXHIBIT AREA	DESCRIPTION	SUPPLIER MANUFACTURER FABRICATOR	FINISH/PATTERN/COLOR
Acrylic	F1	Introduction	Infinity mirror	Canal Plastics	2 Way Mirror
	F2	Introduction	Infinity mirror	Canal Plastics	Mirrored Plexi on Backer
	F3	What We Can See	Displays in "A Changing Planet" Center Display	Canal Plastics	Clear Plexi
Aluminum	F4	What We Can See	aluminum truss wrapped in dichoric film	Cross Fire Staging Rentals	aluminum truss wrapped in dichoric film
	F17	Atomic Mayhem	aluminum frame for ceiling		Framing
	F5	Introduction	aluminum triangles		
Costum inflatable	F6	Cosmic Scale	Inflatable sphere with transparent hexagonal shape outline for "THE SUN" light ficture	Planet Inflatables fabricator to advice	inside shapes must be opaque. inflatable will be painted to look like the Sun
Wood	F7	What We Can See	used to frame activty "How We See."	La Noble	1/8" Balsa Wood painted scenic painted activity
	F8	What is A fractal?	used to frame activty "withn the bloodstream."	La Noble	1/8" Balsa Wood painted scenic painted activity
Flooring	F10	Atomic Mayhem	Preassure sensitive mat		track foot prints when people step fabricator to advice
Laminates	F11	Atomic Mayhem	area sign	DICHROLAM	Iridized film
	F12	Cosmic Scale	area sign	DICHROLAM	Iridized hammered film
	F13	What Is A Fractal?	area sign	DICHROLAM	Iridized Glass monochromatic blues film
	F14	What We Can See	area sign	DICHROLAM	Multicolored Dichoric Glass Film
	F15	What We Can See	"A Changing Planet"	DICHROLAM	Multicolored Dichoric Glass Film
	F16	What We Can See	Patterned Frames	DICHROLAM	Multicolored Dichoric Glass Film
	F18	Cosmic Scale	temporary vinyl flooring	Digital Design	Costum "Cosmos" Graphics to be adhered to subfloor
Fabric Paper	F19	Cosmic Scale	Costum printed graphics on flag banners hanging down inbetween comuns	Digital Design	Costum "Cosmos" graphics
	F20	Atomic Mayhem	Representon of the "nucleus"	Procédés Chénel	Drop Cieling w/ Origami Center & walls

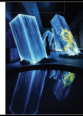

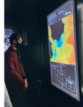
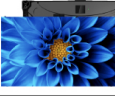





Eve Frudakis Exhibition and Experience Design EXHIBITION DOCUMENTATION	Fashion Institute of Technology School of Graduate Studies 272 West 27th St. New York, NY 10011	Project: 	Client: 	DISCLAIMER This is an unpublished and proprietary work simultaneously protected under copyright, trade secret, and like laws of the United States and other countries. All rights reserved. These materials may not be reproduced, displayed, distributed, nor may be the information therein be used or disclosed in whole or in part, without the express written permission of Eve Frudakis.	Key Plan: Title: <i>Specification List</i>	Scale: Drawn by: <i>Eve Frudakis</i> Date: <i>11.03.2021</i>	EX 203 Drawing NO.
--	---	---	--	---	--	--	------------------------------



:: A/V Schedule

SYMBOL	EXHIBIT AREA	DESCRIPTION	SPECIFICATION	PRODUCER		NOTES
AV1	What We Can See	Audio "how we see" activity	Directed Audio Speaker (x2)	Panphonics		Placed in carparmet in center of box
AV2	What We Can See	"A changing planet" sensor screen	55" XE4F-M Series High Brightness Outdoor Displays (x4)	Sony		Works withLeap Motion Controller with SDK made by Adafruit
AV3	What We Can See		Motion Controller with SDK	Adafruit		x4
AV4	What is a Fractal?	Media Cubes (5)		Fabricated byTeam Lab		
AV5	What is a Fractal?	"Within the blood stream"	Directed Audio Speaker	Panphonics		
AV6	What is a Fractal?	"Within the blood stream"	Freestanding Display 33"	SONY		
AV7	What is a Fractal?	"Fractal Labs"		ArtTech House		reuse
AV8	Atomic Mayhem	Stackable interactive wall screens to create wall	ZRD-2 Stackable tile wall by SONY	SONY		
AV9	What We Can See	Video 1 Screen 1	Nasa Climate time machine: Sea Ice over time	Nasa Video data analysis (visitors control time w/ sensor)		
AV10	What We Can See	Video 2 Screen 2	Nasa Climate time machine: Sea level over time	Nasa Video data analysis (visitors control time w/ sensor)		
AV11	What We Can See	Video 3 Screen 3	Nasa Climate time machine: Carbon dioxide over time	Nasa Video data analysis (visitors control time w/ sensor)		
AV12	What We Can See	Video 4 Screen 4	Nasa Climate time machine: Global temperature over time	Nasa Video data analysis (visitors control time w/ sensor)		

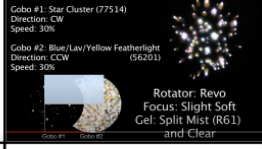

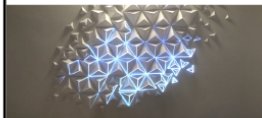







Eve Frudakis Exhibition and Experience Design EXHIBITION DOCUMENTATION	Fashion Institute of Technology School of Graduate Studies 272 West 27th St. New York, NY 10011	Project: 	Client: 	DISCLAIMER This is an unpublished and proprietary work simultaneously protected under copyright, trade secret, and like laws of the United States and other countries. All rights reserved. These materials may not be reproduced, displayed, distributed, nor may be the information therein be used or disclosed in whole or in part, without the express written permission of Eve Frudakis.	Key Plan: 	Title: Area Introduction	Scale:	EX 204 Drawing NO.
							Drawn by: Eve Frudakis Date: 11.03.2021	

:: Lighting Schedule

SYMBOL	EXHIBIT AREA	DESCRIPTION	SPECIFICATION	PRODUCER	NOTES	PHOTO
L1	What We Can See	Up Lighting (x18)	Sun3 Round LED Recessed Uplight/steplight 47 degree angle 3" round	Lightology		
L8	What We Can See	Truss lighting	VOLT® RGBW Max All-Star™ Integrated LED Spotlight (Aluminum Black)	VOLT		
L2	Atomic Mayhem	Rod LED's create (x4) frames	350cm attached with winch system made by producer in pink	Kinetic Lights	Included winches	
L3	Cosmic Scale	Super bright daylight inside inflatable to look like the sun. Effect: daylight comes out on striking angles through hexagonal cracks		COLOR SOURCE PAR	to be mounted on circular track within the atmosphere	
L4	What is a Fractal?	Gel Film placed over preexisting light fixtures within the frames of te minskoff theatre	Rosco Gel Sheets pink to blue ombre	Rosco		
L5	What is a Fractal?	"within in the bloodstream" activity. Red slowly pulsing light timed with audio	Gantom DMX V2 DMX Controlled Spotlight	Gantom		
L6	Cosmic Scale	Second Ceiling Opening.	X-Effect LED projector	Rosco	(X4) Mounted in opening to face all directions NOTE* Use attached gobos #1: Star Cluster (77514) direction: CW speed: 30% #2: Blue/lave/Yellow Featherlight Direction CCW Speed: 30%	 
L8	Cosmic Scale	Reel EFX DF-50 DMX	Reel EFX DF-50 DMX DIFFUSION HAZER	Reel EFX		
L7	Atomic Mayhem	Placed on inside of origami paper on each fold on wall and ceiling to create project mapping twinkle effect	Scenex Lighting WHITE LED pixel tape 118"x.4"	German Light Products		 

Eve Frudakis <i>Exhibition and Experience Design</i>	Fashion Institute of Technology <i>School of Graduate Studies</i> 272 West 27th St. New York, NY 10011	Project: 	Client: 	DISCLAIMER This is an unpublished and proprietary work simultaneously protected under copyright, trade secret, and like laws of the United States and other countries. All rights reserved. These materials may not be reproduced, displayed, distributed, nor may be the information therein be used or disclosed in whole or in part, without the express written permission of Eve Frudakis.	Key Plan:	Title: Area Introduction	Scale:	EX 205 Drawing NO.
							Drawn by: <i>Eve Frudakis</i>	
EXHIBITION DOCUMENTATION								

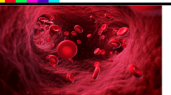
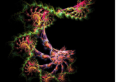
:: Artifact List

SYMBOL	ARTIFACT	EXHIBIT AREA	DESCRIPTION	PHOTO
A1	Ecosphere	What We Can See	The Ecosphere, or self-sustaining habitat, explores conditions necessary to sustain life. Algae capture energy from sunlight and, in turn, are eaten by shrimp. The waste from the shrimp then fertilizes the algae.	
A2	"Antarctic & Southern Elephant Skulls" Large photo	What We Can See Display 1	Photo caption "In 2018, antarctic has again shrunk to it's lowest level on record. By 2100 global sea level rise could turn hundreds of millions of humans into climate refugees."	
A3	"Disposable sunset" Large photo	What We Can See Display 2	Photo caption: "It's estimated by 2050 there will be more plastic than fish in the oceans."	
A4	"Constellation 1" Large photo	What We Can See Display 3	Photo caption: "Ocean acidification due to global warming could destroy 90% of Earth's coral reefs by 2050"	
A5	"Snow leopard 1"	What We Can See Display 4	Photo caption: " There are less than 4000 snow leopards left on the planet as climate change continues to reduce their habitat. their only predator is man."	
A6	The Brain fractal 10 -1	What is a fractal? Media cube 1	Brain Fractal	
A7	Human eye fractal 10 -2	What is a fractal? Media cube 2	Eye Fractal	
A8	Wave lengths of visible light 10 -7	What is a fractal? Media cube 3	The human eye sees only visible light. all the colors of the rainbow are produced by light w/ wavelengths between 400 and 70000 nanometers	
A9	Blood stream image 10-6 to -8	What is a fractal?	"within the bloodstream" activity	
A10	DNA fract 10 -9	What is a fractal? Media cube 4	dna fractal	
A11	Trifid Nebula	Cosmic Scale		

:: PLANS AND SECTIONS

:::LOCATION PLAN



Eve Frudakis
Exhibition and Experience Design

EXHIBITION DOCUMENTATION

Fashion Institute of Technology
School of Graduate Studies
272 West 27th St.
New York, NY 10011

Project:

CATALYST
Made of Stars

Client:



DISCLAIMER

This is an unpublished and proprietary work simultaneously protected under copyright, trade secret, and like laws of the United States and other countries. All rights reserved. These materials may not be reproduced, displayed, distributed, nor may be the information therein be used or disclosed in whole or in part, without the express written permission of Eve Frudakis.

Key Plan:

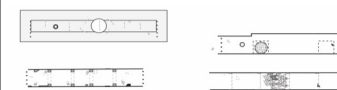

Title:

Location Plan

Scale:



EX 300

Drawn by: Eve Frudakis

Date: 11.03.2021

Drawing NO.

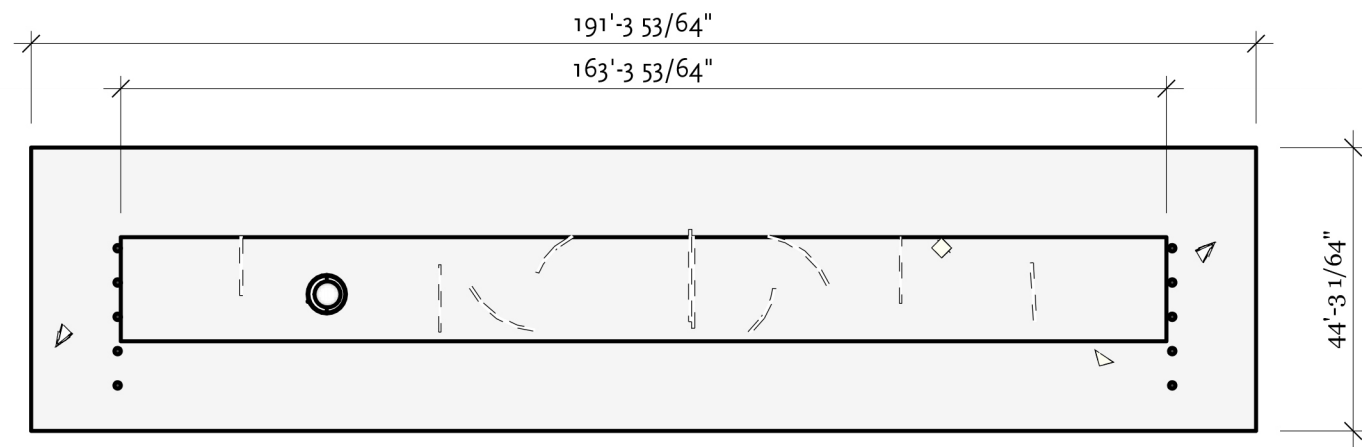

1 :: What We Can See **01A**
 ::Location:: Shubert Alley btw 44th & 45th st. New York NY 10036
 scale: N/A

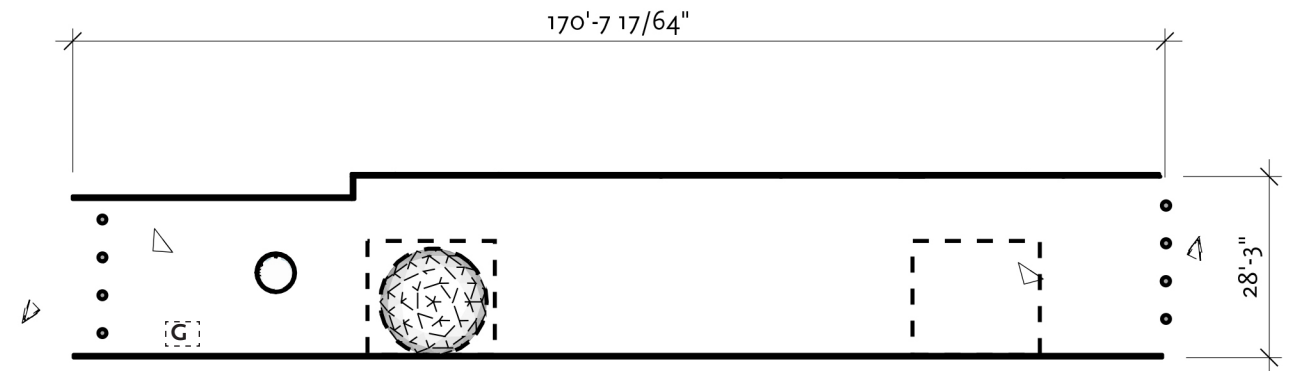

3 :: What is a Fractal? **04A**
 ::Location:: 200 W 45th St, New York, NY 10036 Minscuff Theatre underpass
 scale: N/A

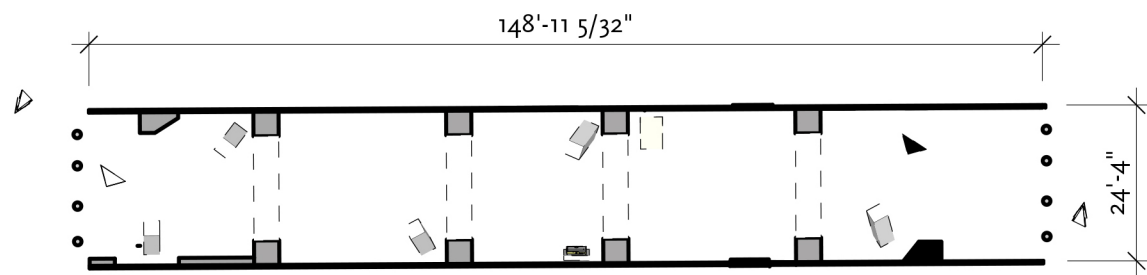

2 :: What is a Fractal? **02A**
 ::Location:: 200 W 45th St, New York, NY 10036 Minscuff Theatre underpass
 scale: N/A

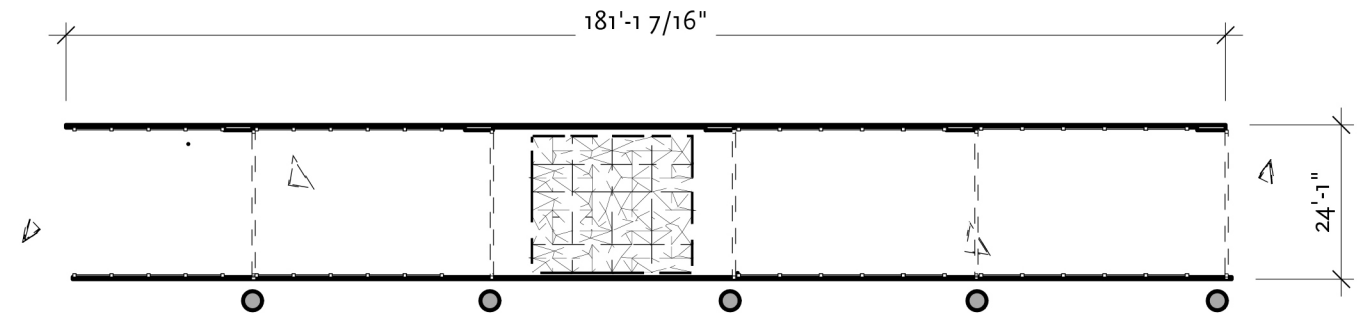

4 :: Cosmic Scale **03A**
 ::Location:: James M. Nederlander Alley 46th st. Side of Marriott Marquis btw Broadway & 8th Ave. 10036
 scale: N/A

Eve Frudakis Exhibition and Experience Design EXHIBITION DOCUMENTATION	Fashion Institute of Technology School of Graduate Studies 272 West 27th St. New York, NY 10011	Project: CATALYST <i>Made of Stars</i>	Client: AMERICAN MUSEUM OF NATURAL HISTORY	DISCLAIMER This is an unpublished and proprietary work simultaneously protected under copyright, trade secret, and like laws of the United States and other countries. All rights reserved. These materials may not be reproduced, displayed, distributed, nor may be the information therein be used or disclosed in whole or in part, without the express written permission of Eve Frudakis.	Key Plan: 	Title: <i>Site Plan</i>	Scale: N/S	EX 301 Drawing NO.
							Drawn by: Eve Frudakis Date: 11.03.2021	

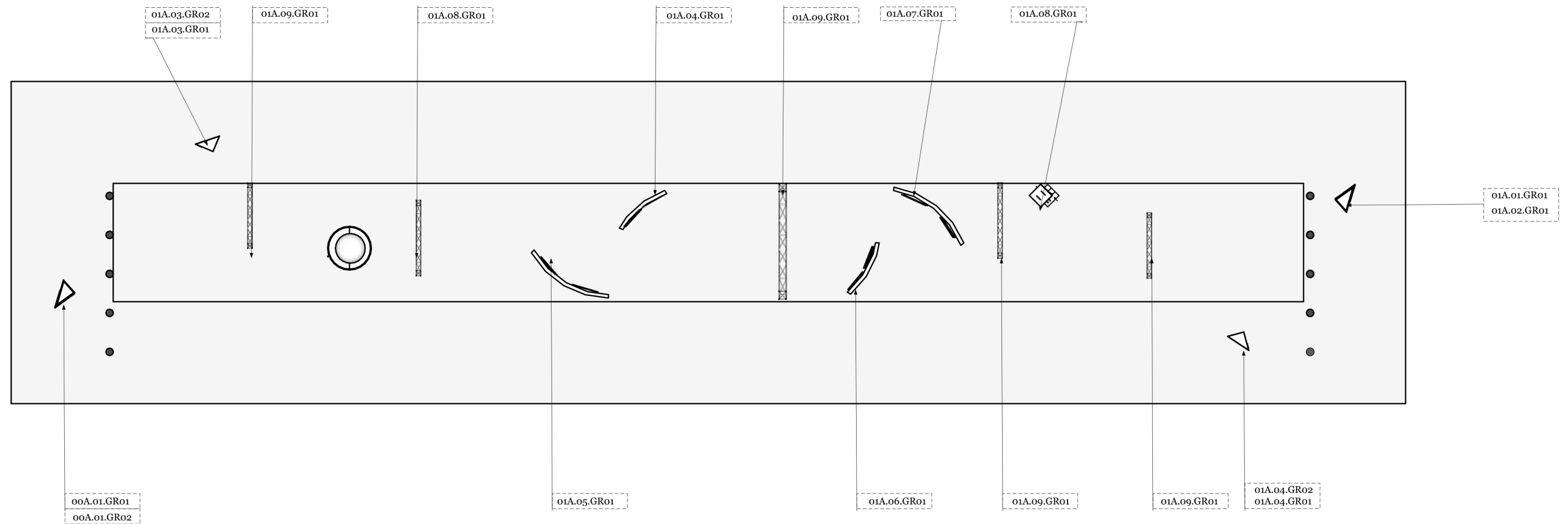



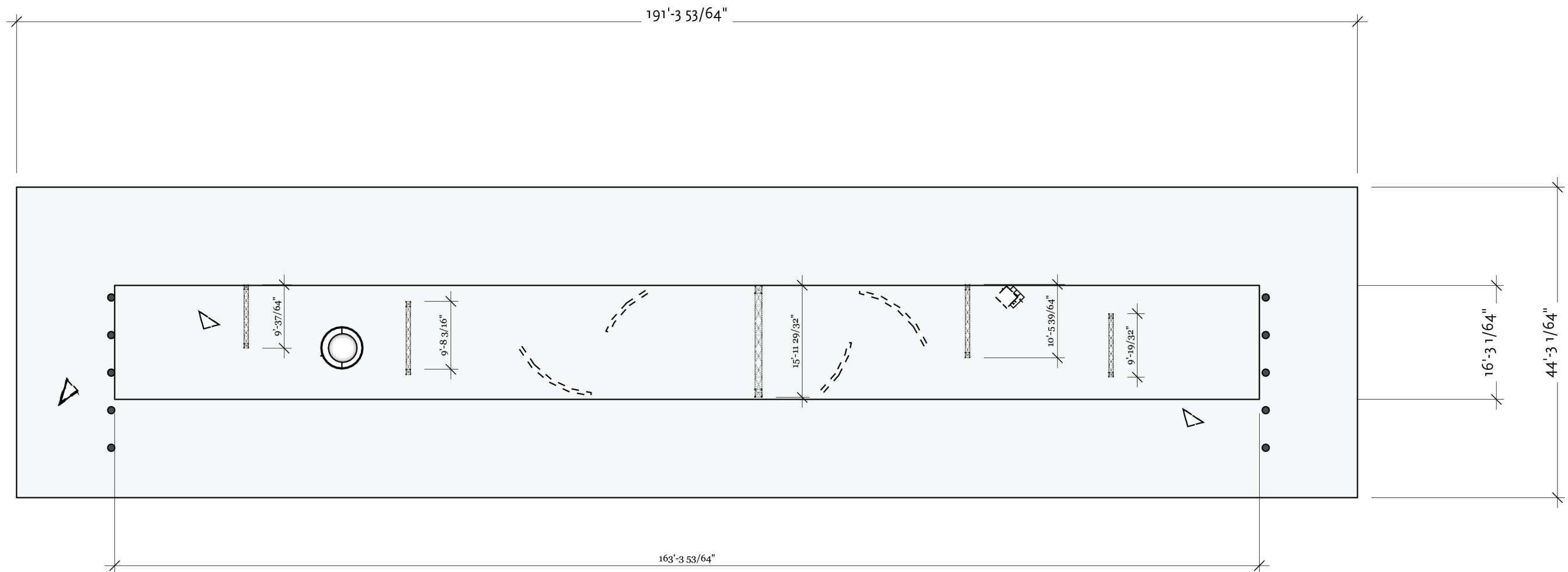

1 :: Graphic Location Plan
 ::Location:: Shubert Alley btw 44th & 45th st. New York NY 10036
 scale: 1/16" = 1'

Eve Frudakis <i>Exhibition and Experience Design</i> EXHIBITION DOCUMENTATION	Fashion Institute of Technology <i>School of Graduate Studies</i> 272 West 27th St. New York, NY 10011	Project: 	Client: 	DISCLAIMER This is an unpublished and proprietary work simultaneously protected under copyright, trade secret, and like laws of the United States and other countries. All rights reserved. These materials may not be reproduced, displayed, distributed, nor may be the information therein be used or disclosed in whole or in part, without the express written permission of Eve Frudakis.	Key Plan: 	Title: <i>Graphic Location Plan</i> 01A	Scale: 1/16" = 1'	EX 302 Drawing NO.

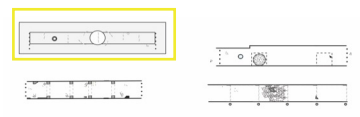

1 :: Dimension Area 01A
 ::Location:: Shubert Alley btw 44th & 45th st. New York NY 10036
 scale: 1/16 = 1'

Eve Frudakis <i>Exhibition and Experience Design</i>	Fashion Institute of Technology <i>School of Graduate Studies</i> 272 West 27th St. New York, NY 10011	Project: 	Client: 	DISCLAIMER <small>This is an unpublished and proprietary work simultaneously protected under copyright, trade secret, and like laws of the United States and other countries. All rights reserved. These materials may not be reproduced, displayed, distributed, nor may be the information therein be used or disclosed in whole or in part, without the express written permission of Eve Frudakis.</small>	Key Plan: 	Title: <i>Dimension Area 01A</i>	Scale: 1/16 = 1' Drawn by: <i>Eve Frudakis</i> Date: 11.03.2021	 EX 303 Drawing NO.
--	--	---	--	--	---	--	---	--

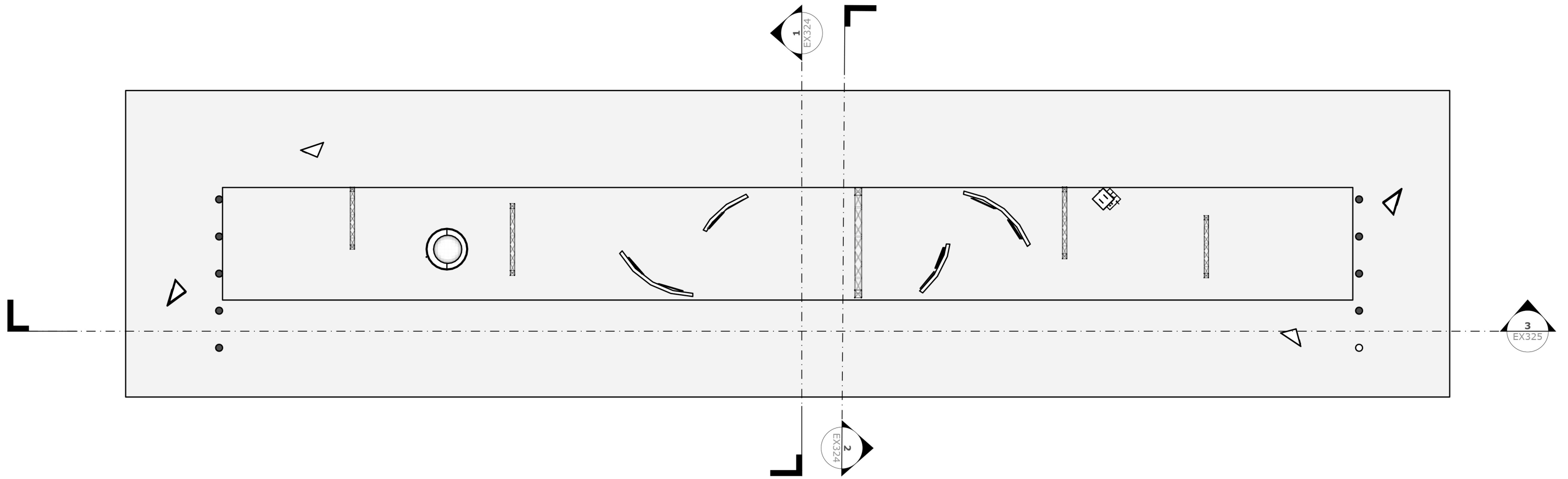

1 :: Coded Floor Plan Area 01A
 ::Location:: Shubert Alley btw 44th & 45th st. New York NY 10036
 scale: 1/16 = 1'

Eve Frudakis <i>Exhibition and Experience Design</i> EXHIBITION DOCUMENTATION	Fashion Institute of Technology <i>School of Graduate Studies</i> 272 West 27th St. New York, NY 10011	Project: CATALYST <i>Made of Stars</i>	Client: 	DISCLAIMER This is an unpublished and proprietary work simultaneously protected under copyright, trade secret, and like laws of the United States and other countries. All rights reserved. These materials may not be reproduced, displayed, distributed, nor may be the information therein be used or disclosed in whole or in part, without the express written permission of Eve Frudakis.	Key Plan: 	Title: Coded Floor Plan 01A	Scale: 1/16 = 1' Drawn by: <i>Eve Frudakis</i> Date: 11.03.2021	 EX 304 Drawing NO.

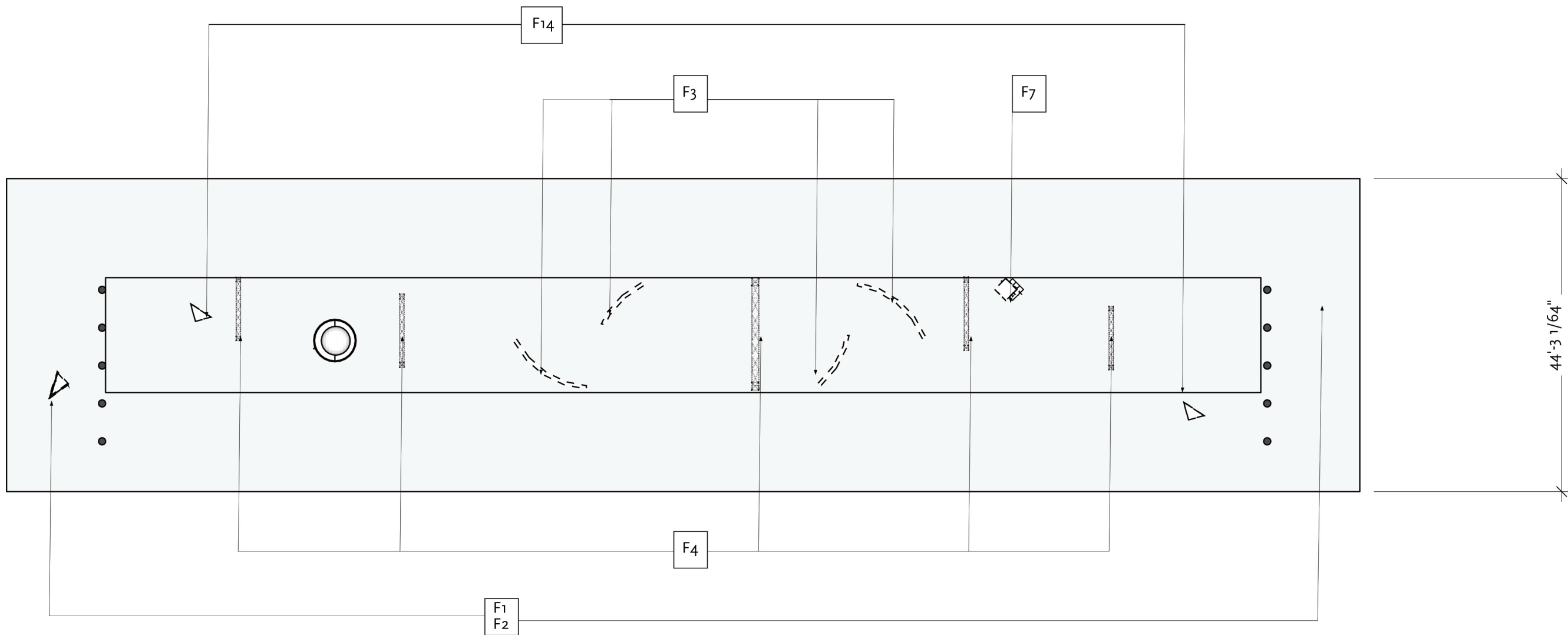



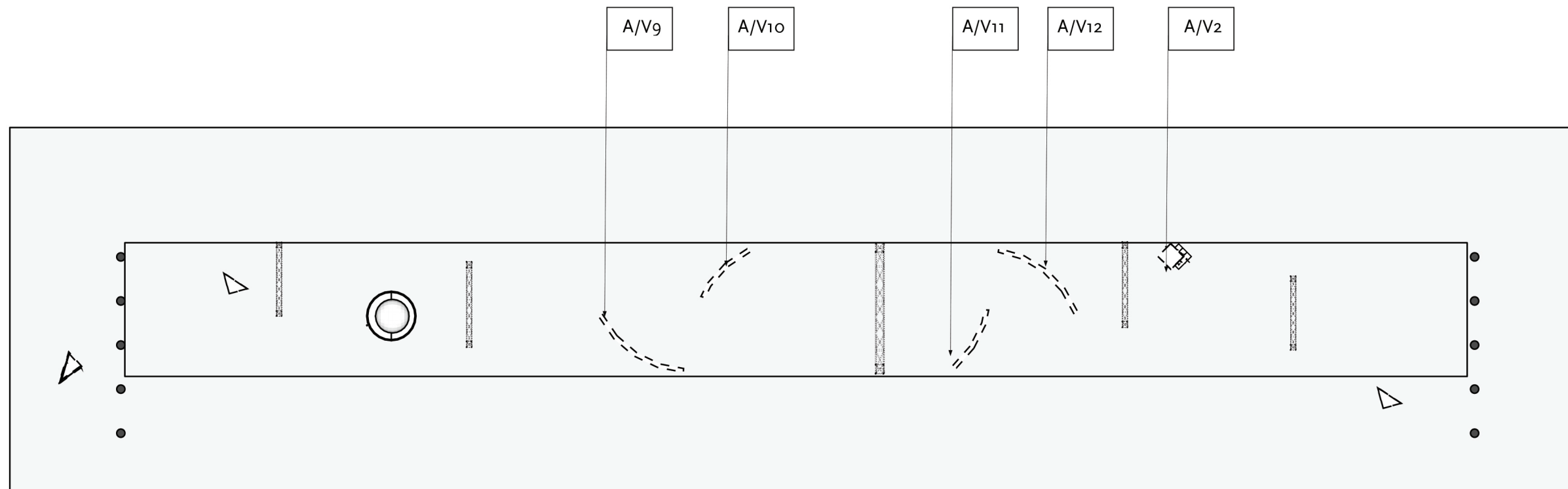

1 :: Finish Plan Area 01A
 ::Location:: Shubert Alley btw 44th & 45th st. New York NY 10036
 scale: 1/16 = 1'

Eve Frudakis <i>Exhibition and Experience Design</i>	Fashion Institute of Technology <i>School of Graduate Studies</i> 272 West 27th St. New York, NY 10011	Project:	Client:	DISCLAIMER <small>This is an unpublished and proprietary work simultaneously protected under copyright, trade secret, and like laws of the United States and other countries. All rights reserved. These materials may not be reproduced, displayed, distributed, nor may be the information therein be used or disclosed in whole or in part, without the express written permission of Eve Frudakis.</small>	Key Plan: 	Title: <i>Finish Plan 01A</i>	Scale: 1/16 = 1'		EX 305
		CATALYST <i>Made of Stars</i>		Date: 11.03.2021	Drawing NO.				

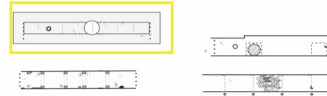

1 :: Media Plan Area 01A
 ::Location:: Shubert Alley btw 44th & 45th st. New York NY 10036
 scale: 1/16 = 1'

Eve Frudakis <i>Exhibition and Experience Design</i>	Fashion Institute of Technology <i>School of Graduate Studies</i> 272 West 27th St. New York, NY 10011	Project: 	Client: 	DISCLAIMER <small>This is an unpublished and proprietary work simultaneously protected under copyright, trade secret, and like laws of the United States and other countries. All rights reserved. These materials may not be reproduced, displayed, distributed, nor may be the information therein be used or disclosed in whole or in part, without the express written permission of Eve Frudakis.</small>	Key Plan: 	Title: <i>Media Plan 01A</i>	Scale: 1/16 = 1' Drawn by: <i>Eve Frudakis</i> Date: 11.03.2021	 EX 306 Drawing NO.
--	--	---	--	--	---	--	---	--

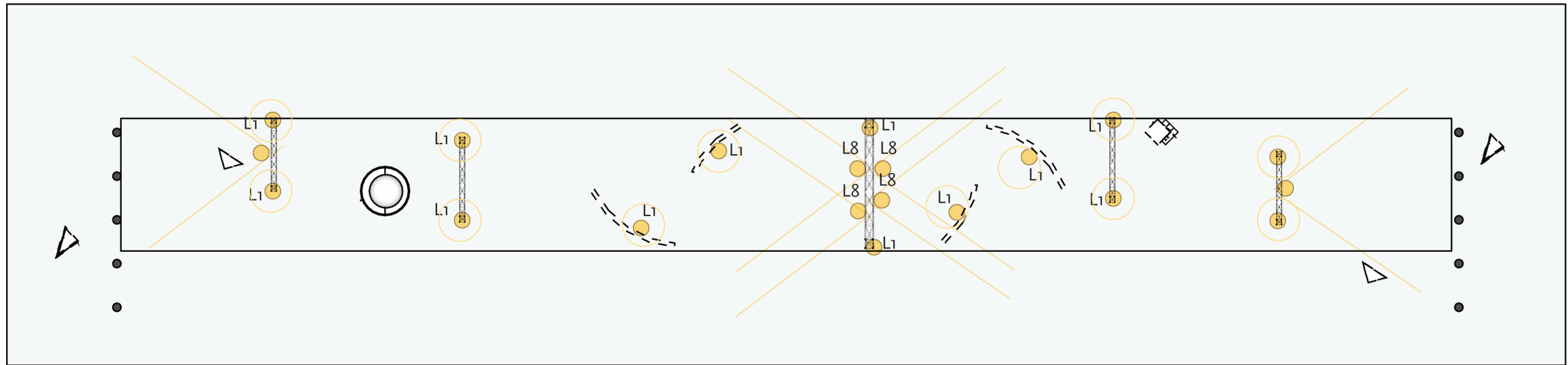

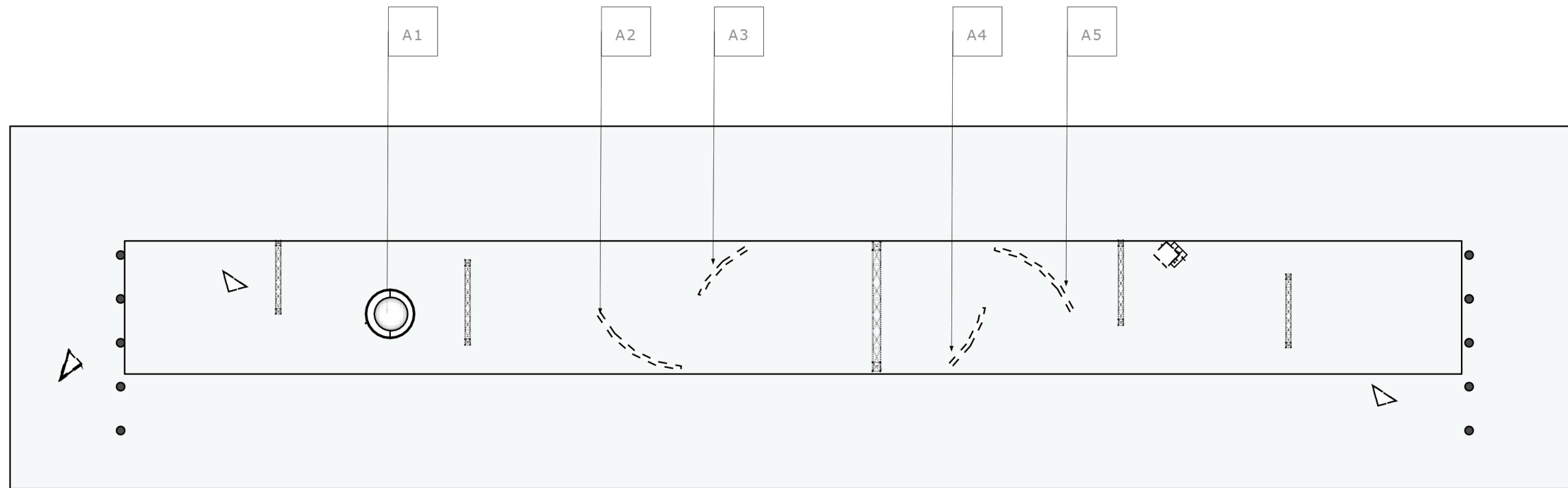

1 :: RCP Area 01A
 ::Location:: Shubert Alley btw 44th & 45th st. New York NY 10036
 scale: 1/16 = 1'

Eve Frudakis <i>Exhibition and Experience Design</i>	Fashion Institute of Technology <i>School of Graduate Studies</i> 272 West 27th St. New York, NY 10011	Project: 	Client: 	DISCLAIMER This is an unpublished and proprietary work simultaneously protected under copyright, trade secret, and like laws of the United States and other countries. All rights reserved. These materials may not be reproduced, displayed, distributed, nor may be the information therein be used or disclosed in whole or in part, without the express written permission of Eve Frudakis.	Key Plan: 	Title: RCP 01A	Scale: 1/16 = 1' Drawn by: <i>Eve Frudakis</i> Date: 11.03.2021	 EX 307 Drawing NO.
--	--	---	--	---	---	-------------------	--	--

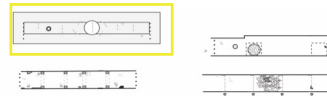

1 :: Artifact Plan Area 01A
 ::Location:: Shubert Alley btw 44th & 45th st. New York NY 10036
 scale: 1/16" = 1'

<p>Eve Frudakis <i>Exhibition and Experience Design</i></p> <hr/> <p>EXHIBITION DOCUMENTATION</p>	<p>Fashion Institute of Technology <i>School of Graduate Studies</i> 272 West 27th St. New York, NY 10011</p>	<p>Project:</p> <div style="border: 2px solid black; padding: 5px; text-align: center;"> <p>CATALYST <i>Made of Stars</i></p> </div>	<p>Client:</p> 	<p>DISCLAIMER This is an unpublished and proprietary work simultaneously protected under copyright, trade secret, and like laws of the United States and other countries. All rights reserved. These materials may not be reproduced, displayed, distributed, nor may be the information therein be used or disclosed in whole or in part, without the express written permission of Eve Frudakis.</p>	<p>Key Plan:</p> 	<p>Title: <i>Artifact Plan 01A</i></p>	<p>Scale: 1/16" = 1'</p> <hr/> <p>Drawn by: <i>Eve Frudakis</i></p> <hr/> <p>Date: 11.03.2021</p>	<div style="text-align: center;">  <p>EX 308</p> <hr/> <p>Drawing NO.</p> </div>
--	---	--	--	--	--	---	--	--

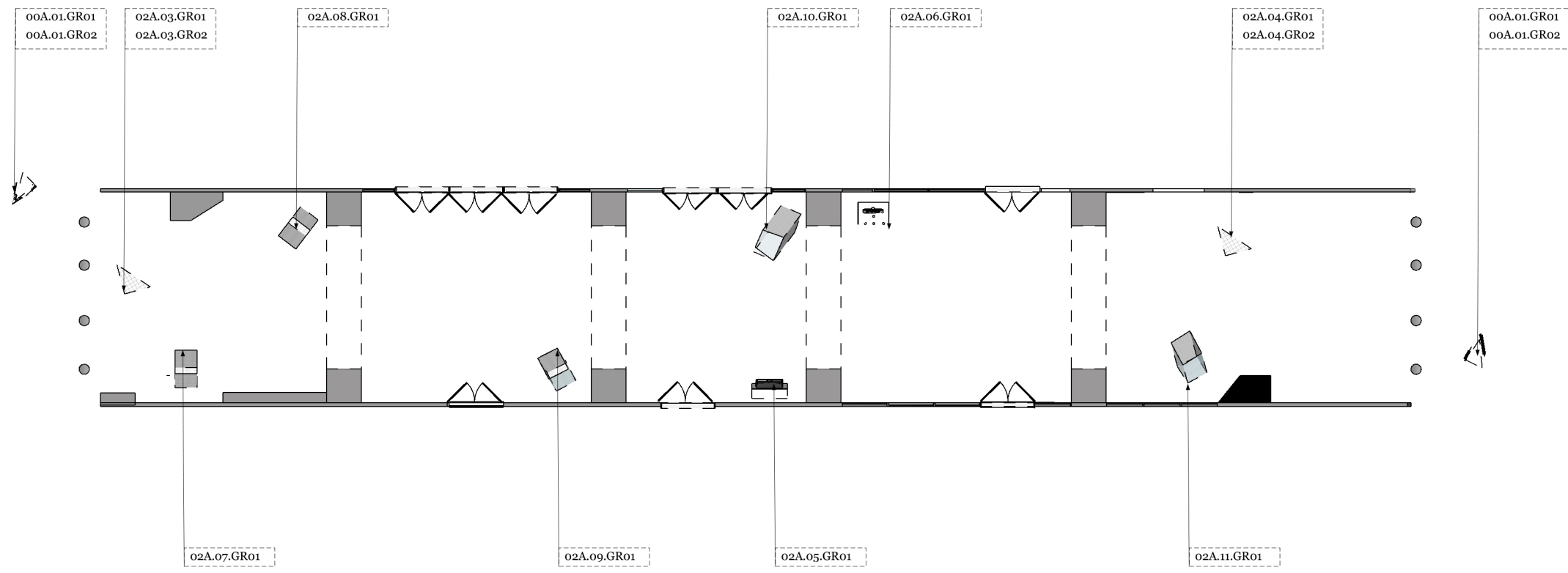

1 :: Graphic Location Plan O2A
 ::Location:: 200 W 45th St, New York, NY 10036 Minsciff Theatre underpass
 scale: 1/16" = 1'

<p>Eve Frudakis <i>Exhibition and Experience Design</i></p> <hr/> <p>EXHIBITION DOCUMENTATION</p>	<p>Fashion Institute of Technology <i>School of Graduate Studies</i> 272 West 27th St. New York, NY 10011</p>	<p>Project:</p> 	<p>Client:</p> 	<p>DISCLAIMER This is an unpublished and proprietary work simultaneously protected under copyright, trade secret, and like laws of the United States and other countries. All rights reserved. These materials may not be reproduced, displayed, distributed, nor may be the information therein be used or disclosed in whole or in part, without the express written permission of Eve Frudakis.</p>	<p>Key Plan:</p> 	<p>Title: <i>Graphic Location Plan</i> o2A</p>	<p>Scale: 1/16" = 1'</p> <p>Drawn by: <i>Eve Frudakis</i></p> <p>Date: 11.03.2021</p> <p>EX 309 Drawing NO.</p>
--	---	---	--	--	--	--	--

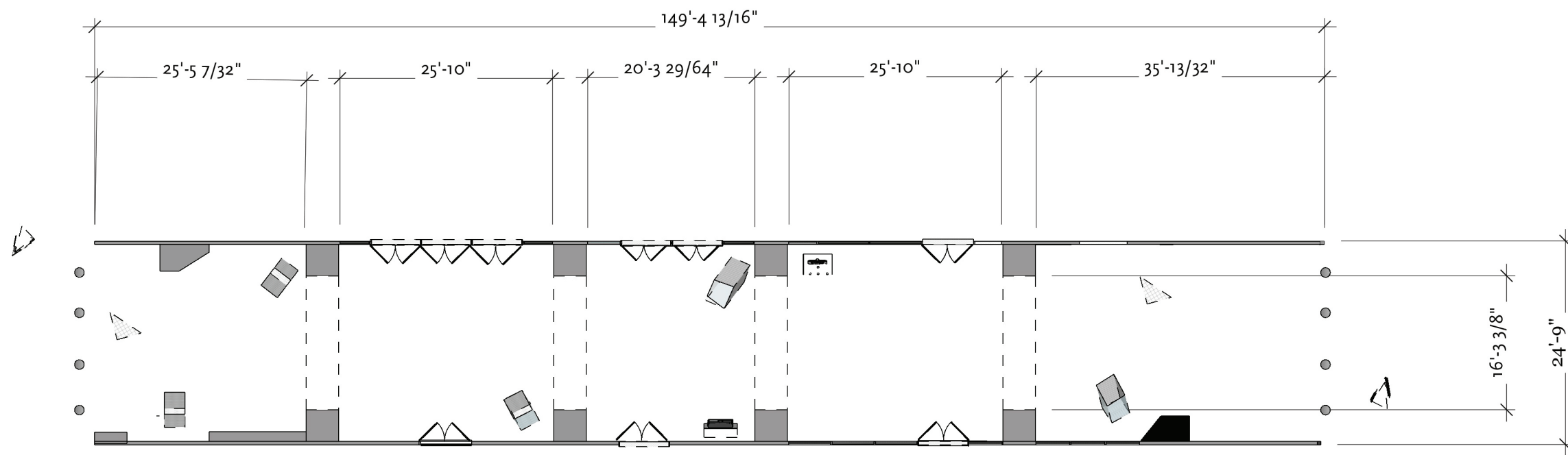

1 :: Dimension Area 02A
 ::Location:: 200 W 45th St, New York, NY 10036 Minsciff Theatre underpass
 scale: 1/16 = 1'

Eve Frudakis Exhibition and Experience Design EXHIBITION DOCUMENTATION	Fashion Institute of Technology School of Graduate Studies 272 West 27th St. New York, NY 10011	Project: CATALYST <i>Made of Stars</i>	Client: 	DISCLAIMER This is an unpublished and proprietary work simultaneously protected under copyright, trade secret, and like laws of the United States and other countries. All rights reserved. These materials may not be reproduced, displayed, distributed, nor may be the information therein be used or disclosed in whole or in part, without the express written permission of Eve Frudakis.	Key Plan: 	Title: Dimensions Area 02A	Scale: 1/16 = 1'	EX 310 Drawing NO.
							Drawn by: <i>Eve Frudakis</i> Date: 11.03.2021	

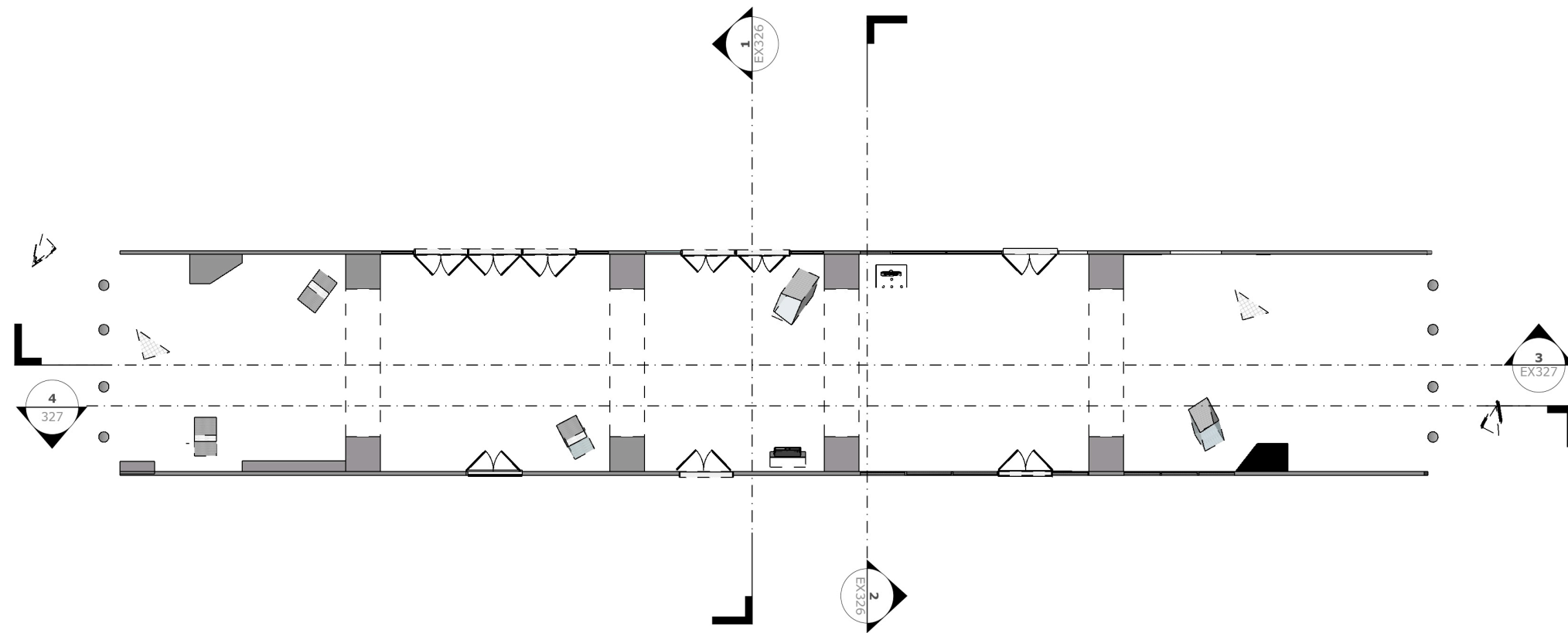

1 :: Coded Floor Plan Area 02A
 ::Location:: 200 W 45th St, New York, NY 10036 Minsciff Theatre underpass
 scale: 1/16 = 1'

Eve Frudakis <i>Exhibition and Experience Design</i>	Fashion Institute of Technology <i>School of Graduate Studies</i> 272 West 27th St. New York, NY 10011	Project:	Client:	DISCLAIMER This is an unpublished and proprietary work simultaneously protected under copyright, trade secret, and like laws of the United States and other countries. All rights reserved. These materials may not be reproduced, displayed, distributed, nor may be the information therein be used or disclosed in whole or in part, without the express written permission of Eve Frudakis.	Key Plan: 	Title: <i>Coded Floor Plan 02A</i>	Scale: 1/16 = 1'		EX 311
		CATALYST <i>Made of Stars</i>		Drawn by: <i>Eve Frudakis</i>	Date: 11.03.2021	Drawing NO.			

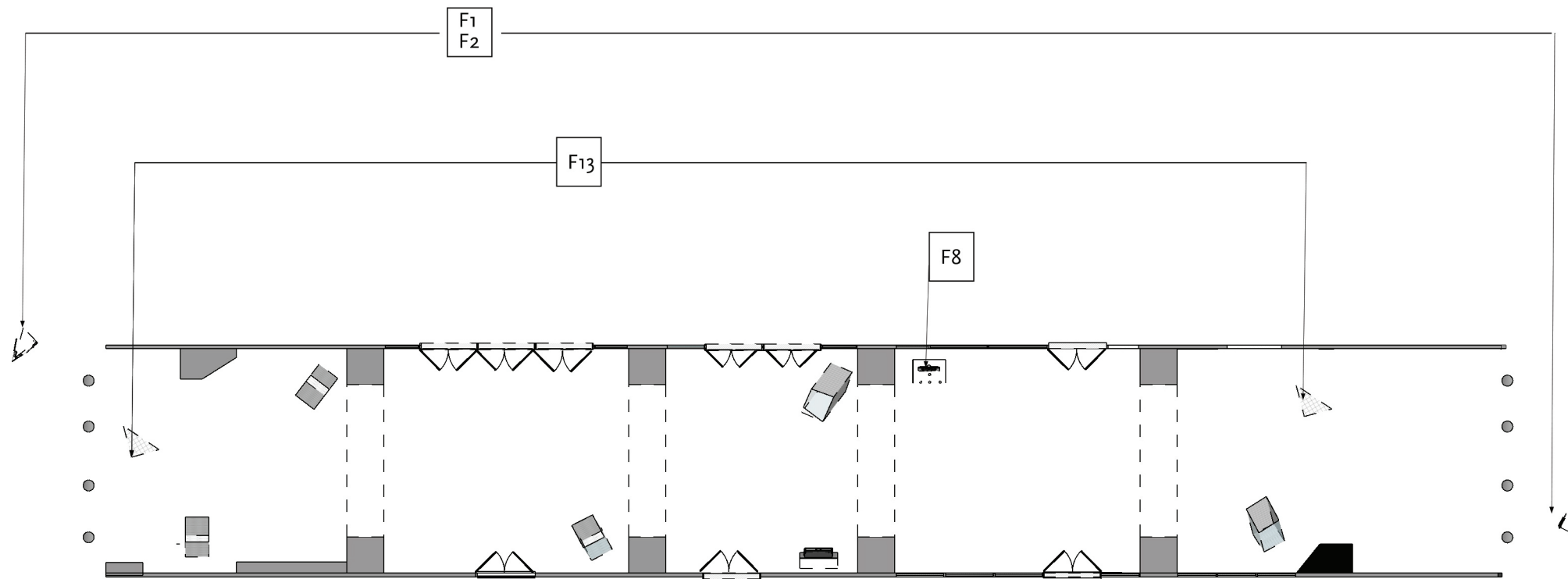

1 :: Finish Plan Area 02A
 ::Location:: 200 W 45th St, New York, NY 10036 Minsciff Theatre underpass
 scale: 1/16 = 1'

<p>Eve Frudakis <i>Exhibition and Experience Design</i></p> <p>EXHIBITION DOCUMENTATION</p>	<p>Fashion Institute of Technology <i>School of Graduate Studies</i> 272 West 27th St. New York, NY 10011</p>	<p>Project:</p> <p>CATALYST <i>Made of Stars</i></p>	<p>Client:</p> <p> AMERICAN MUSEUM OF NATURAL HISTORY</p>	<p>DISCLAIMER This is an unpublished and proprietary work simultaneously protected under copyright, trade secret, and like laws of the United States and other countries. All rights reserved. These materials may not be reproduced, displayed, distributed, nor may be the information therein be used or disclosed in whole or in part, without the express written permission of Eve Frudakis.</p>	<p>Key Plan:</p>	<p>Title: <i>Finish Plan Area 02A</i></p>	<p>Scale: 1/16 = 1'</p> <p>Drawn by: <i>Eve Frudakis</i></p> <p>Date: 11.03.2021</p>	<p></p> <p>EX 312</p> <p>Drawing NO.</p>
--	---	--	---	--	------------------	--	---	---

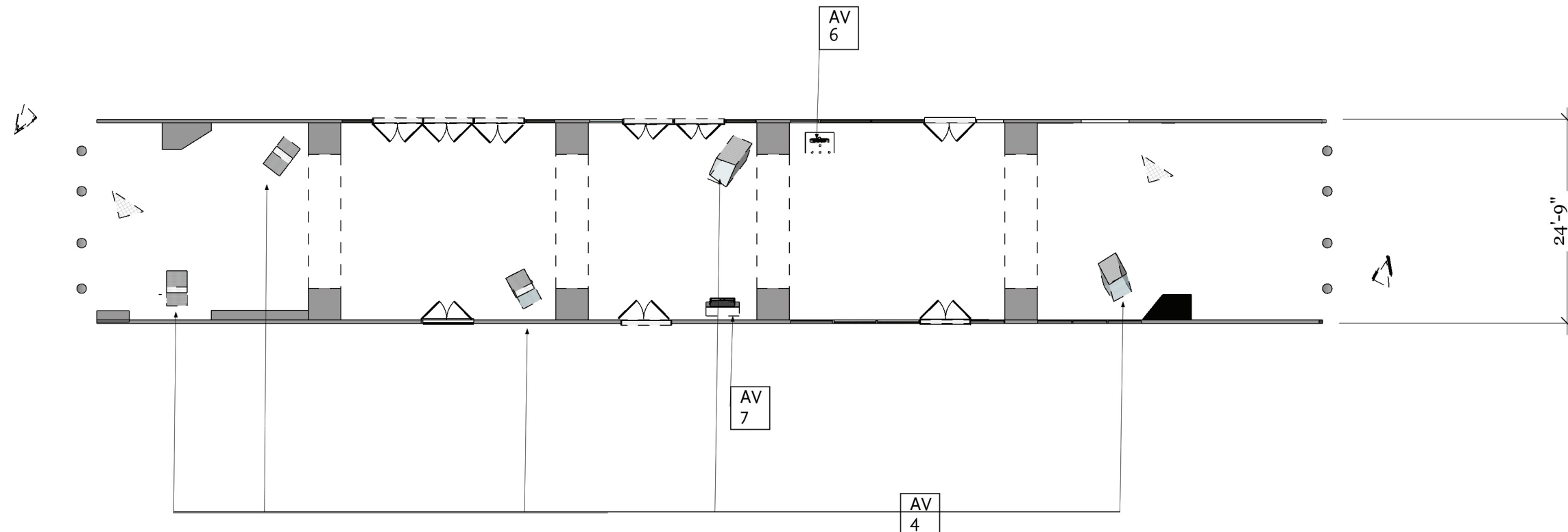

1 :: Media Plan Area 02A
 ::Location:: 200 W 45th St, New York, NY 10036 Minsciff Theatre underpass
 scale: 1/16 = 1'

Eve Frudakis <i>Exhibition and Experience Design</i>	Fashion Institute of Technology <i>School of Graduate Studies</i> 272 West 27th St. New York, NY 10011	Project:	Client:	DISCLAIMER This is an unpublished and proprietary work simultaneously protected under copyright, trade secret, and like laws of the United States and other countries. All rights reserved. These materials may not be reproduced, displayed, distributed, nor may be the information therein be used or disclosed in whole or in part, without the express written permission of Eve Frudakis.	Key Plan: 	Title: <i>Media Plan Area 02A</i>	Scale: 1/16 = 1'		EX 313
		CATALYST <i>Made of Stars</i>	AMERICAN MUSEUM & NATURAL HISTORY	EXHIBITION DOCUMENTATION	Drawn by: <i>Eve Frudakis</i> Date: 11.03.2021	Drawing NO.			

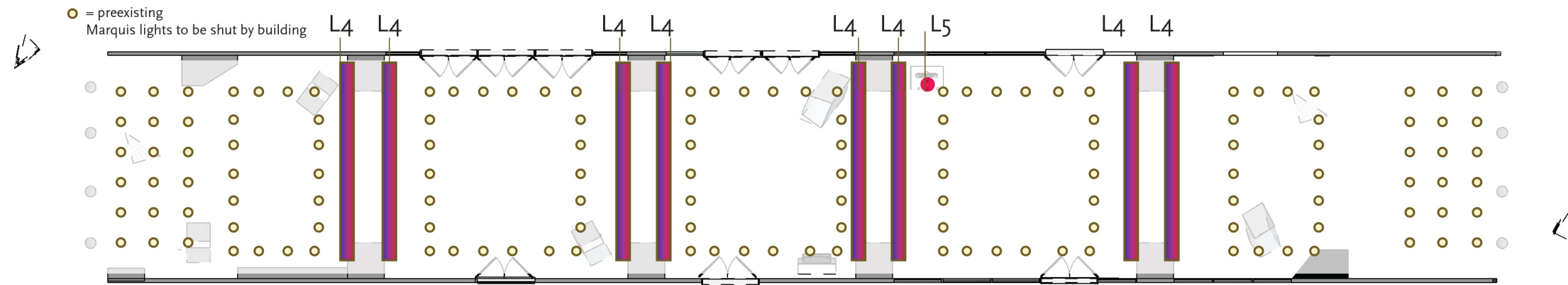

1 :: RCP Area 02A
 ::Location:: 200 W 45th St, New York, NY 10036 Minsciff Theatre underpass
 scale: 1/16 = 1'

<p>Eve Frudakis <i>Exhibition and Experience Design</i></p> <hr/> <p>EXHIBITION DOCUMENTATION</p>	<p>Fashion Institute of Technology <i>School of Graduate Studies</i> 272 West 27th St. New York, NY 10011</p>	<p>Project:</p> 	<p>Client:</p> 	<p>DISCLAIMER This is an unpublished and proprietary work simultaneously protected under copyright, trade secret, and like laws of the United States and other countries. All rights reserved. These materials may not be reproduced, displayed, distributed, nor may be the information therein be used or disclosed in whole or in part, without the express written permission of Eve Frudakis.</p>	<p>Key Plan:</p> 	<p>Title: <i>RCP 02A</i></p>	<p>Scale: 1/16 = 1'</p> <p>Drawn by: <i>Eve Frudakis</i></p> <p>Date: 11.03.2021</p>	 <p>EX 314</p> <p>Drawing NO.</p>
--	---	---	--	--	--	-----------------------------------	---	---

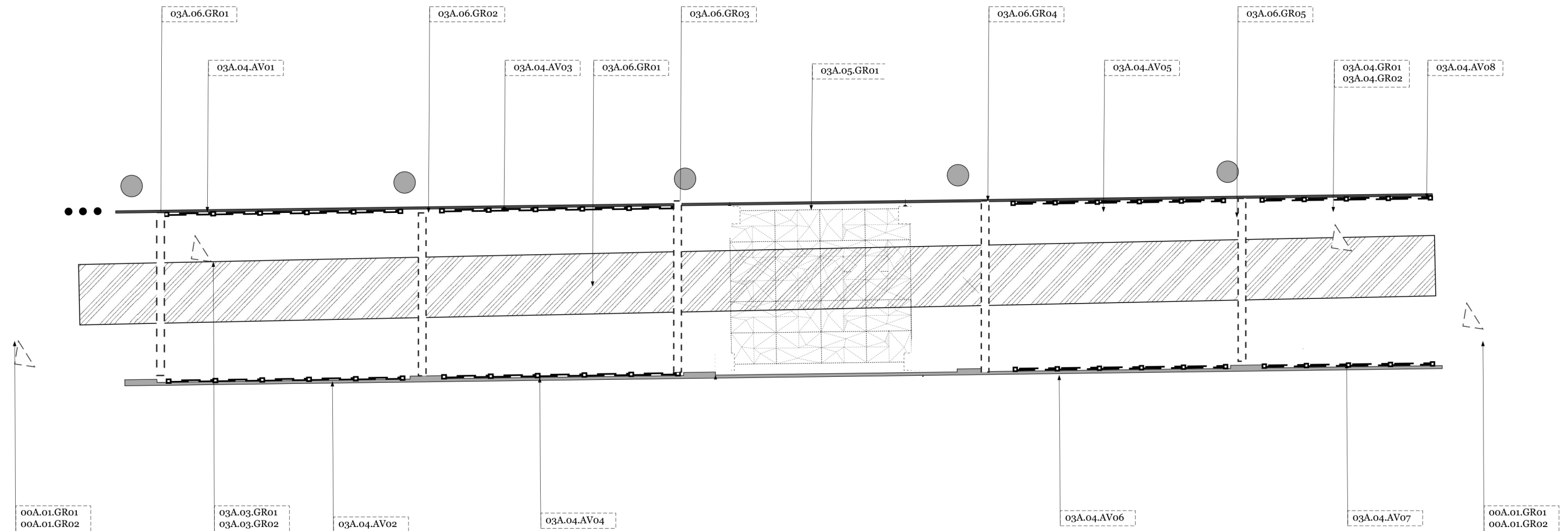

1 :: Graphic Location Plan 03A
 ::Location:: The Marriott Marquis Parking Lot 1535 Broadway
 scale: 1/16" = 1'

Eve Frudakis <i>Exhibition and Experience Design</i> EXHIBITION DOCUMENTATION	Fashion Institute of Technology <i>School of Graduate Studies</i> 272 West 27th St. New York, NY 10011	Project: 	Client: 	DISCLAIMER This is an unpublished and proprietary work simultaneously protected under copyright, trade secret, and like laws of the United States and other countries. All rights reserved. These materials may not be reproduced, displayed, distributed, nor may be the information therein be used or disclosed in whole or in part, without the express written permission of Eve Frudakis.	Key Plan: 	Title: <i>Graphic Location Plan 03A</i>	Scale: 1/16" = 1'		EX 315
	Drawn by: Eve Frudakis Date: 11.03.2021							Drawing NO.	

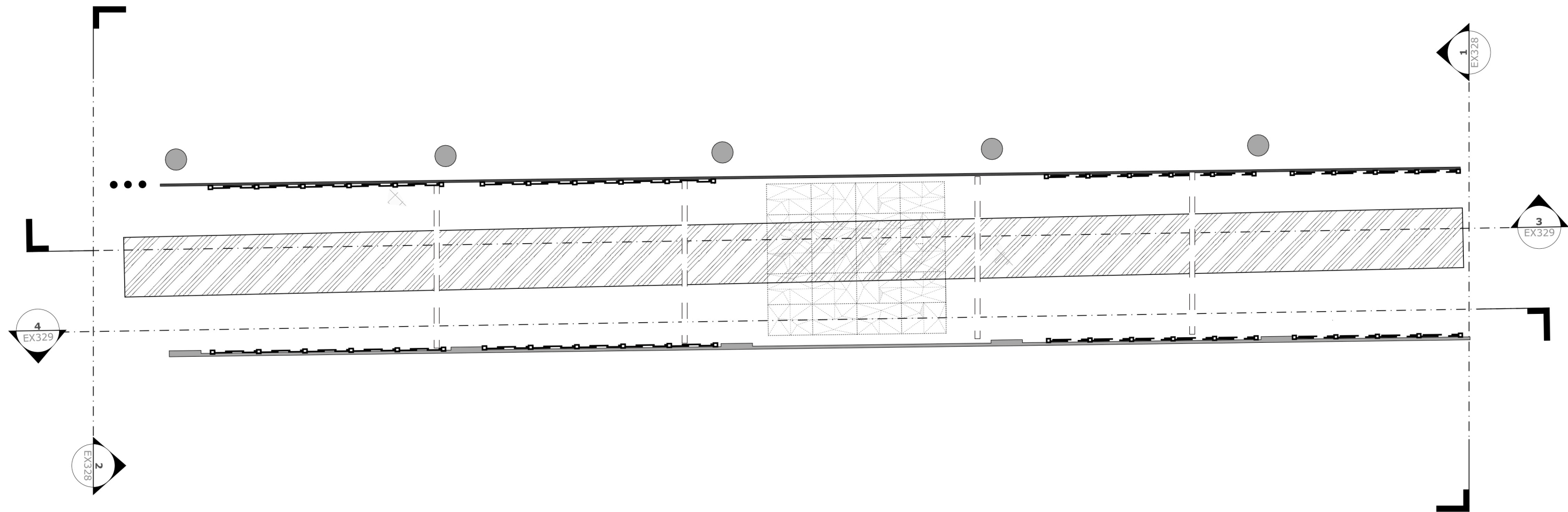

1 :: Coded Floor Plan Area 03 A
 ::Location:: The Marriott Marquis Parking Lot 1535 Broadway
 scale: 1/16 = 1'

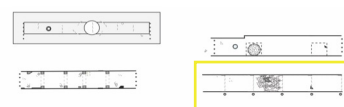
<p>Eve Frudakis <i>Exhibition and Experience Design</i></p> <hr/> <p>EXHIBITION DOCUMENTATION</p>	<p>Fashion Institute of Technology <i>School of Graduate Studies</i> 272 West 27th St. New York, NY 10011</p>	<p>Project:</p> <div style="border: 2px solid black; padding: 5px; text-align: center;"> <p>CATALYST <i>Made of Stars</i></p> </div>	<p>Client:</p> 	<p>DISCLAIMER This is an unpublished and proprietary work simultaneously protected under copyright, trade secret, and like laws of the United States and other countries. All rights reserved. These materials may not be reproduced, displayed, distributed, nor may be the information therein be used or disclosed in whole or in part, without the express written permission of Eve Frudakis.</p>	<p>Key Plan:</p> 	<p>Title: <i>Coded Floor Plan 03A</i></p>	<p>Scale: 1/16 = 1'</p> <p>Drawn by: <i>Eve Frudakis</i></p> <p>Date: 11.03.2021</p>	<div style="border: 1px solid black; padding: 5px;"> <p>EX 316</p> <p>Drawing NO.</p> </div>
--	---	--	--	--	--	--	---	---

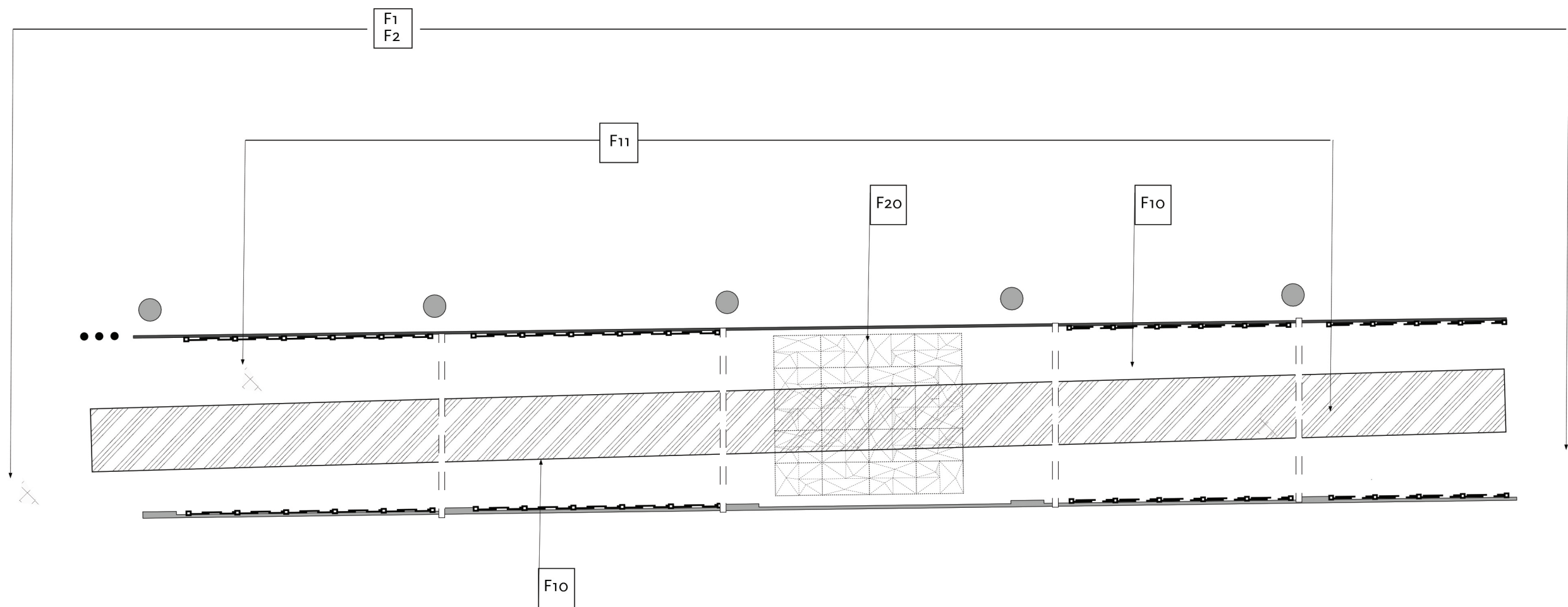

1 :: Finish Plan Area 03A
 ::Location:: The Marriott Marquis Parking Lot 1535 Broadway
 scale: 1/16" = 1'

<p>Eve Frudakis <i>Exhibition and Experience Design</i></p> <hr/> <p>EXHIBITION DOCUMENTATION</p>	<p>Fashion Institute of Technology <i>School of Graduate Studies</i> 272 West 27th St. New York, NY 10011</p>	<p>Project:</p> 	<p>Client:</p> 	<p>DISCLAIMER This is an unpublished and proprietary work simultaneously protected under copyright, trade secret, and like laws of the United States and other countries. All rights reserved. These materials may not be reproduced, displayed, distributed, nor may be the information therein be used or disclosed in whole or in part, without the express written permission of Eve Frudakis.</p>	<p>Key Plan:</p> 	<p>Title: <i>Finish Plan 03A</i></p>	<p>Scale: 1/16" = 1'</p> <p>Drawn by: <i>Eve Frudakis</i></p> <p>Date: 11.03.2021</p>	 <p>EX 317</p> <p>Drawing NO.</p>
--	---	---	--	--	--	---	--	---

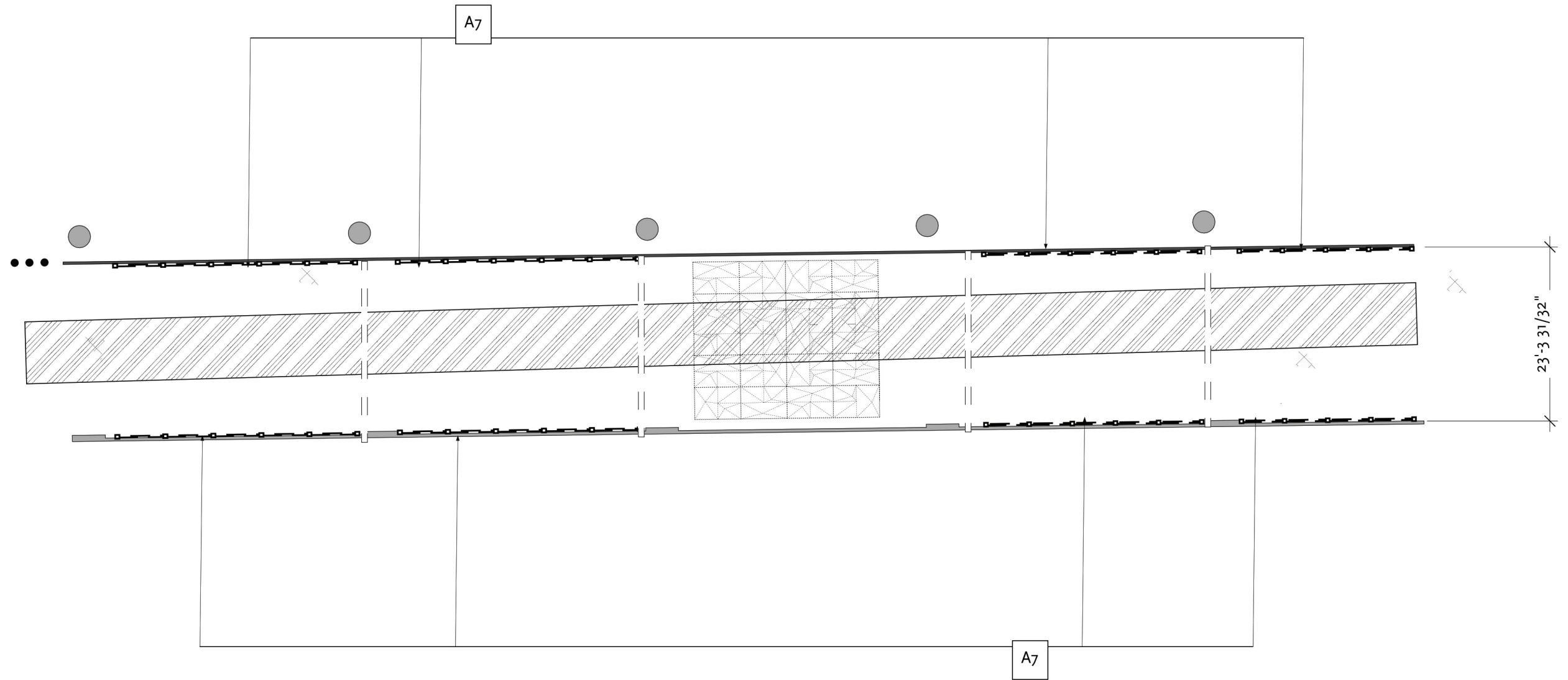

1 :: Media Plan Area 03A
 ::Location:: The Marriott Marquis Parking Lot 1535 Broadway
 scale: 1/16 = 1'

Eve Frudakis
 Exhibition and Experience Design
 EXHIBITION DOCUMENTATION

Fashion Institute of Technology
 School of Graduate Studies
 272 West 27th St.
 New York, NY 10011

Project:
CATALYST
 Made of Stars

Client:
 AMERICAN MUSEUM
 OF NATURAL HISTORY

DISCLAIMER
 This is an unpublished and proprietary work simultaneously protected under copyright, trade secret, and like laws of the United States and other countries. All rights reserved. These materials may not be reproduced, displayed, distributed, nor may be the information therein be used or disclosed in whole or in part, without the express written permission of Eve Frudakis.

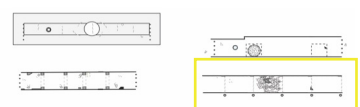
Key Plan:



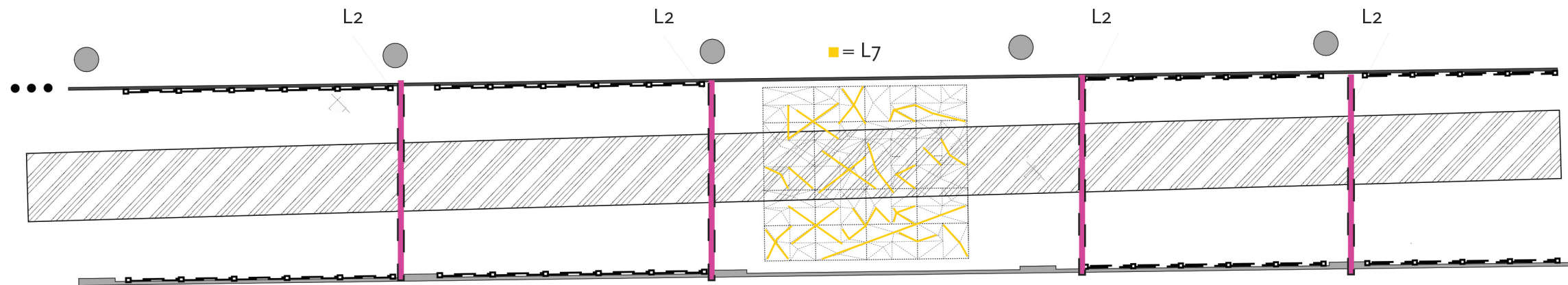

Title:
 Media Plan 03A

Scale:
 1/16 = 1'
 Drawn by: Eve Frudakis
 Date: 11.03.2021

EX 318
 Drawing NO.

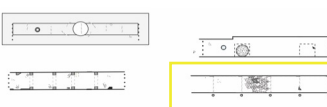

1 :: RCP Area 03A
 ::Location:: The Marriott Marquis Parking Lot 1535 Broadway
 scale: 1/16 = 1'

<p>Eve Frudakis <i>Exhibition and Experience Design</i></p>	<p>Fashion Institute of Technology <i>School of Graduate Studies</i> 272 West 27th St. New York, NY 10011</p>	<p>Project: </p>	<p>Client: </p>	<p>DISCLAIMER This is an unpublished and proprietary work simultaneously protected under copyright, trade secret, and like laws of the United States and other countries. All rights reserved. These materials may not be reproduced, displayed, distributed, nor may be the information therein be used or disclosed in whole or in part, without the express written permission of Eve Frudakis.</p>	<p>Key Plan: </p>	<p>Title: RCP 03A</p>	<p>Scale: 1/16 = 1'</p> <p>Drawn by: <i>Eve Frudakis</i> Date: 11.03.2021</p>	<p> EX 319 Drawing NO.</p>
---	---	--	---	--	---	------------------------------------	---	---

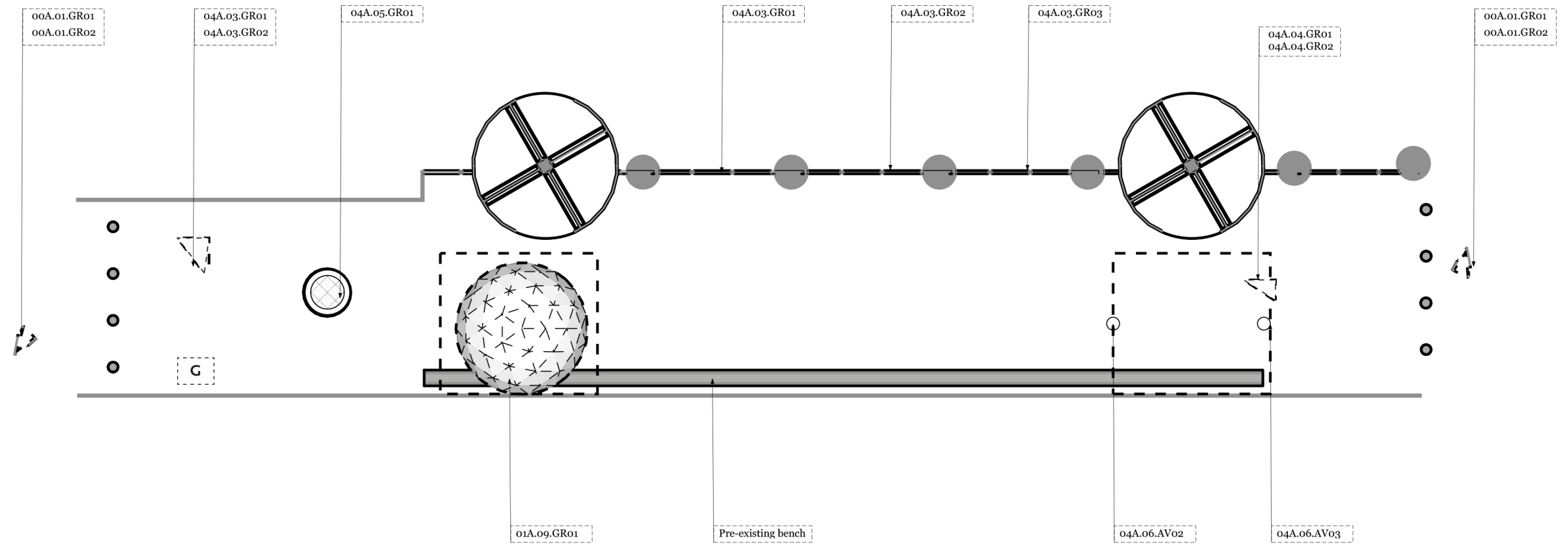

1 :: Graphic Location Plan **04A**
 ::Location:: James M. Nederlander Alley 46th st. Side of Marriott Marquis btw Broadway & 8th Ave. 10036
 scale: 1/16" = 1'

Eve Frudakis <i>Exhibition and Experience Design</i> EXHIBITION DOCUMENTATION	Fashion Institute of Technology <i>School of Graduate Studies</i> 272 West 27th St. New York, NY 10011	Project: CATALYST <i>Made of Stars</i>	Client: 	DISCLAIMER This is an unpublished and proprietary work simultaneously protected under copyright, trade secret, and like laws of the United States and other countries. All rights reserved. These materials may not be reproduced, displayed, distributed, nor may be the information therein be used or disclosed in whole or in part, without the express written permission of Eve Frudakis.	Key Plan: 	Title: <i>Graphic Location Plan</i> 04A	Scale: 1/16" = 1'	EX 320 Drawing NO.
	Drawn by: <i>Eve Frudakis</i> Date: 11.03.2021							

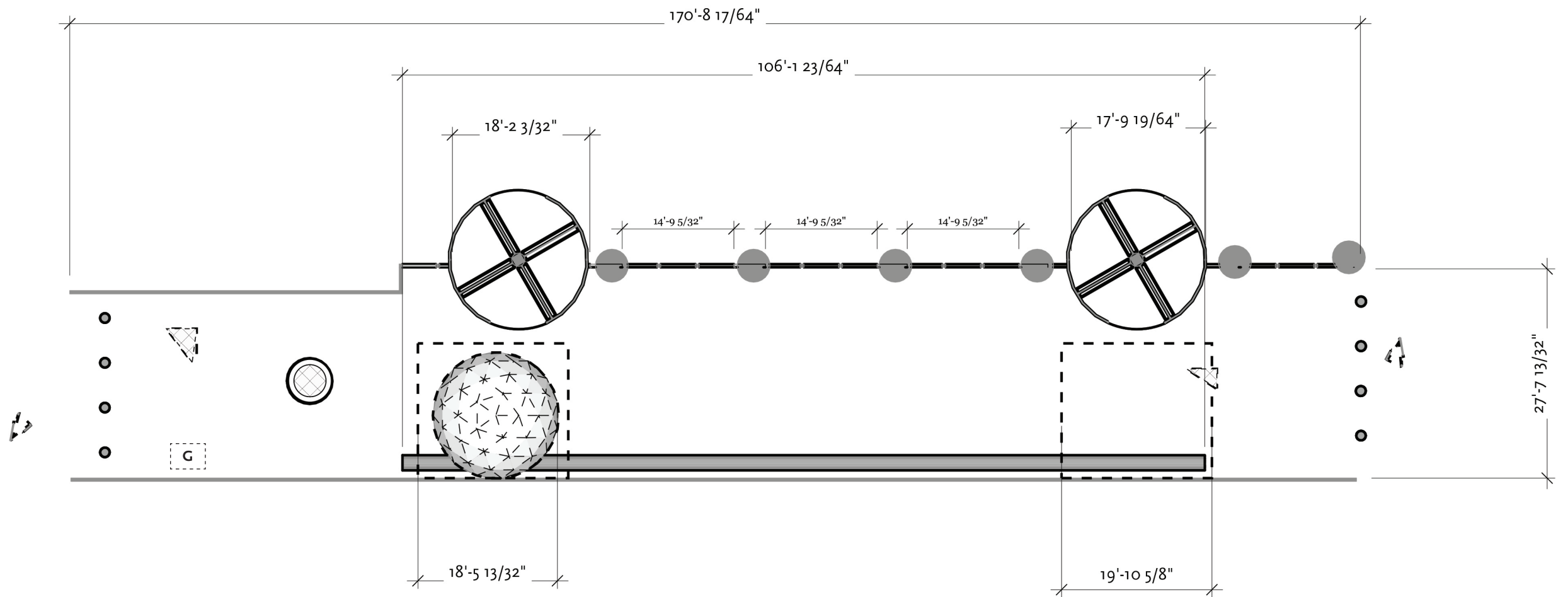

1 :: Dimension Plan Area 04A
 ::Location:: James M. Nederlander Alley 46th st. Side of Marriott Marquis btw Broadway & 8th Ave. 10036
 scale: 1/16 = 1'

Eve Frudakis <i>Exhibition and Experience Design</i>	Fashion Institute of Technology <i>School of Graduate Studies</i> 272 West 27th St. New York, NY 10011	Project:	Client:	DISCLAIMER <small>This is an unpublished and proprietary work simultaneously protected under copyright, trade secret, and like laws of the United States and other countries. All rights reserved. These materials may not be reproduced, displayed, distributed, nor may be the information therein be used or disclosed in whole or in part, without the express written permission of Eve Frudakis.</small>	Key Plan:	Title: <i>Dimension Plan Area 04</i>	Scale: 1/16 = 1'	EX 321
		CATALYST <i>Made of Stars</i>	AMERICAN MUSEUM & NATURAL HISTORY		Drawn by: <i>Eve Frudakis</i> Date: 11.03.2021	Drawing NO.		

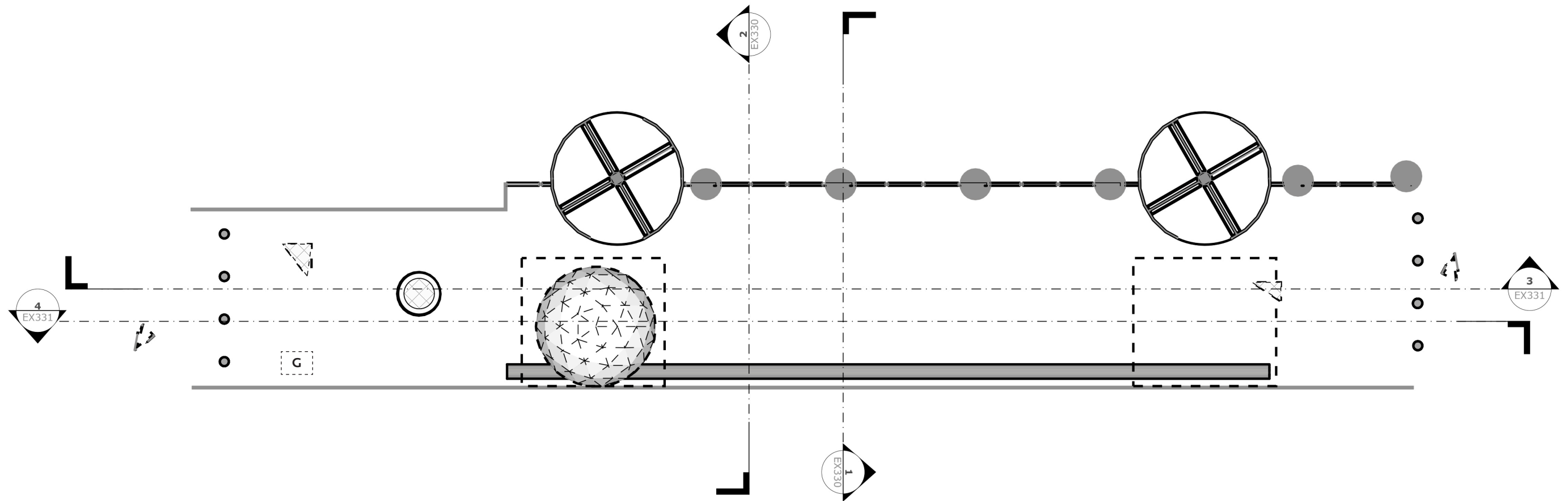

1 :: Coded Floor Plan Area 04A
 ::Location:: James M. Nederlander Alley 46th st. Side of Marriott Marquis btw Broadway & 8th Ave. 10036
 scale: 1/16 = 1'

<p>Eve Frudakis <i>Exhibition and Experience Design</i></p> <p>EXHIBITION DOCUMENTATION</p>	<p>Fashion Institute of Technology <i>School of Graduate Studies</i> 272 West 27th St. New York, NY 10011</p>	<p>Project:</p> <p>CATALYST <i>Made of Stars</i></p>	<p>Client:</p> <p>AMERICAN MUSEUM & NATURAL HISTORY</p>	<p>DISCLAIMER This is an unpublished and proprietary work simultaneously protected under copyright, trade secret, and like laws of the United States and other countries. All rights reserved. These materials may not be reproduced, displayed, distributed, nor may be the information therein be used or disclosed in whole or in part, without the express written permission of Eve Frudakis.</p>	<p>Key Plan:</p>	<p>Title: <i>Coded Floor Plan Area 04A</i></p>	<p>Scale: 1/16 = 1'</p> <p>Drawn by: <i>Eve Frudakis</i></p> <p>Date: 11.03.2021</p>	<p>EX 322</p> <p>Drawing NO.</p>
--	---	--	--	--	------------------	---	---	---

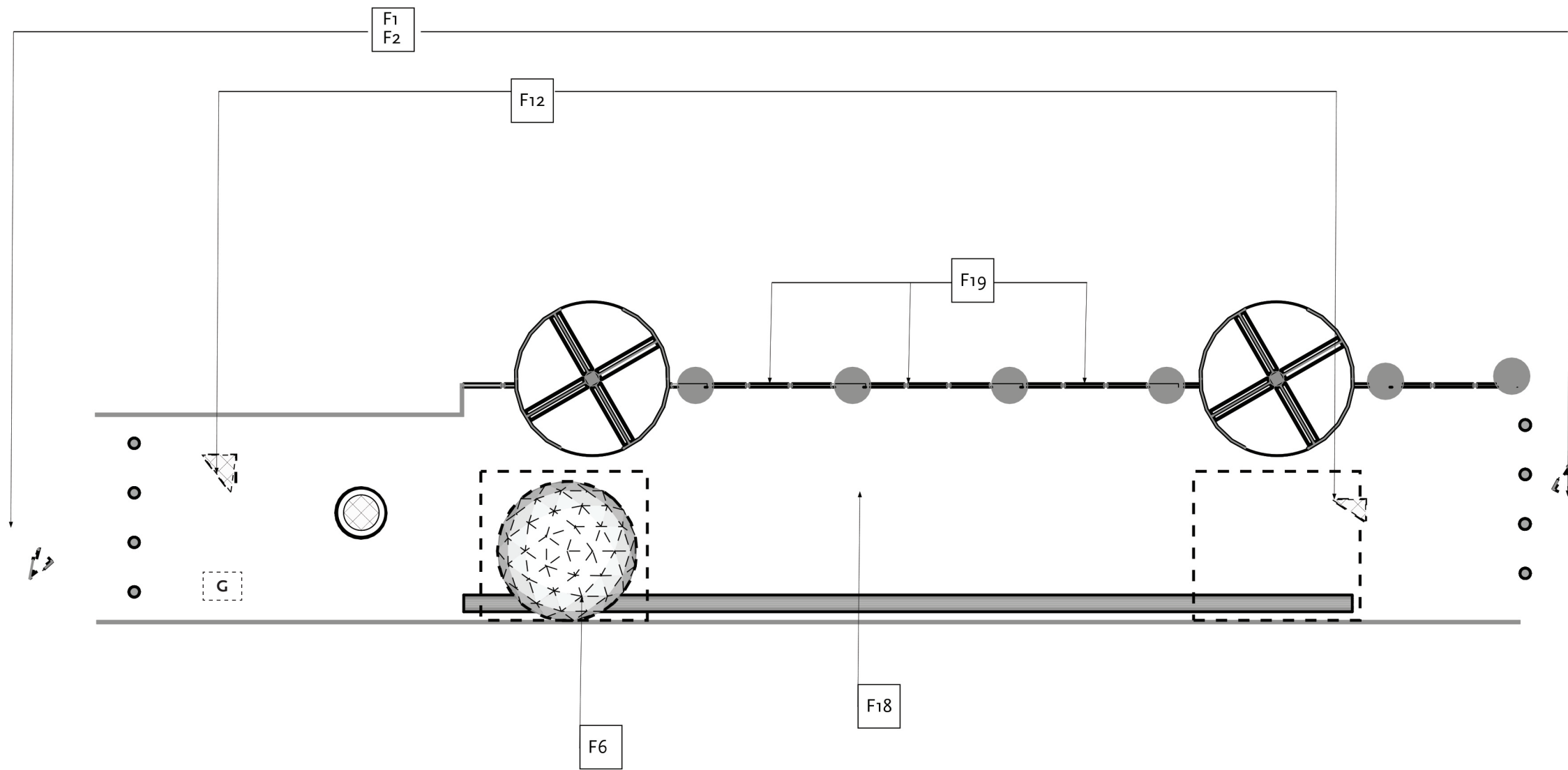



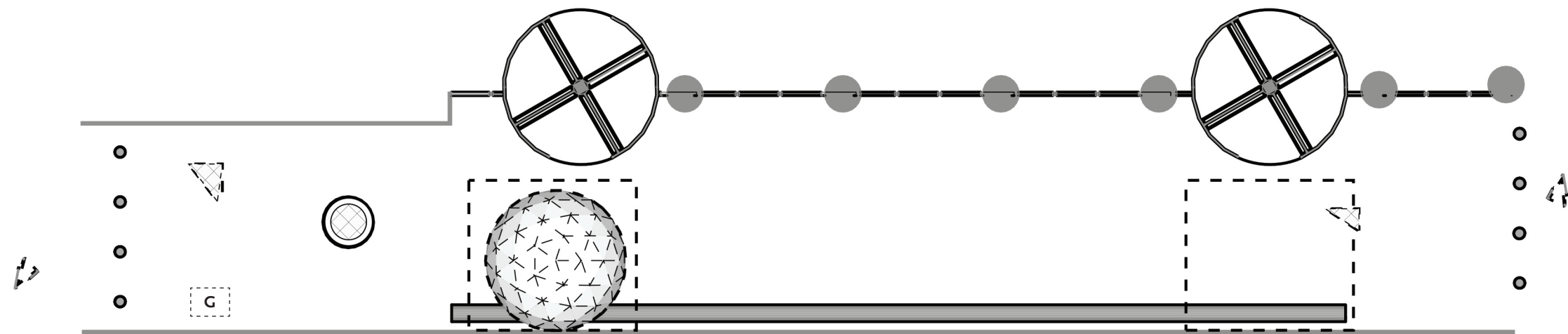

1 :: Finish Plan Area 04A
 ::Location:: James M. Nederlander Alley 46th st. Side of Marriott Marquis btw Broadway & 8th Ave. 10036
 scale: 1/16 = 1'

Eve Frudakis <i>Exhibition and Experience Design</i>	Fashion Institute of Technology <i>School of Graduate Studies</i> 272 West 27th St. New York, NY 10011	Project: 	Client: 	DISCLAIMER This is an unpublished and proprietary work simultaneously protected under copyright, trade secret, and like laws of the United States and other countries. All rights reserved. These materials may not be reproduced, displayed, distributed, nor may be the information therein be used or disclosed in whole or in part, without the express written permission of Eve Frudakis.	Key Plan: 	Title: <i>Finish Plan Area 04A</i>	Scale: 1/16 = 1'		EX 323
							Drawn by: Eve Frudakis Date: 11.03.2021		

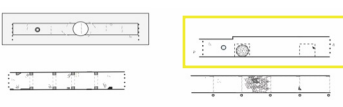

1 :: Media Plan Area 04A
 ::Location:: James M. Nederlander Alley 46th st. Side of Marriott Marquis btw Broadway & 8th Ave. 10036
 scale: 1/16 = 1'

Eve Frudakis <i>Exhibition and Experience Design</i>	Fashion Institute of Technology <i>School of Graduate Studies</i> 272 West 27th St. New York, NY 10011	Project: 	Client: 	DISCLAIMER <small>This is an unpublished and proprietary work simultaneously protected under copyright, trade secret, and like laws of the United States and other countries. All rights reserved. These materials may not be reproduced, displayed, distributed, nor may be the information therein be used or disclosed in whole or in part, without the express written permission of Eve Frudakis.</small>	Key Plan: 	Title: <i>Media Plan 04A</i>	Scale: 1/16 = 1' Drawn by: <i>Eve Frudakis</i> Date: 11.03.2021	 EX 324 Drawing NO.
--	--	---	--	--	--	---------------------------------	--	--

● =preexisting light
 ** Marquis lights to be shut by building

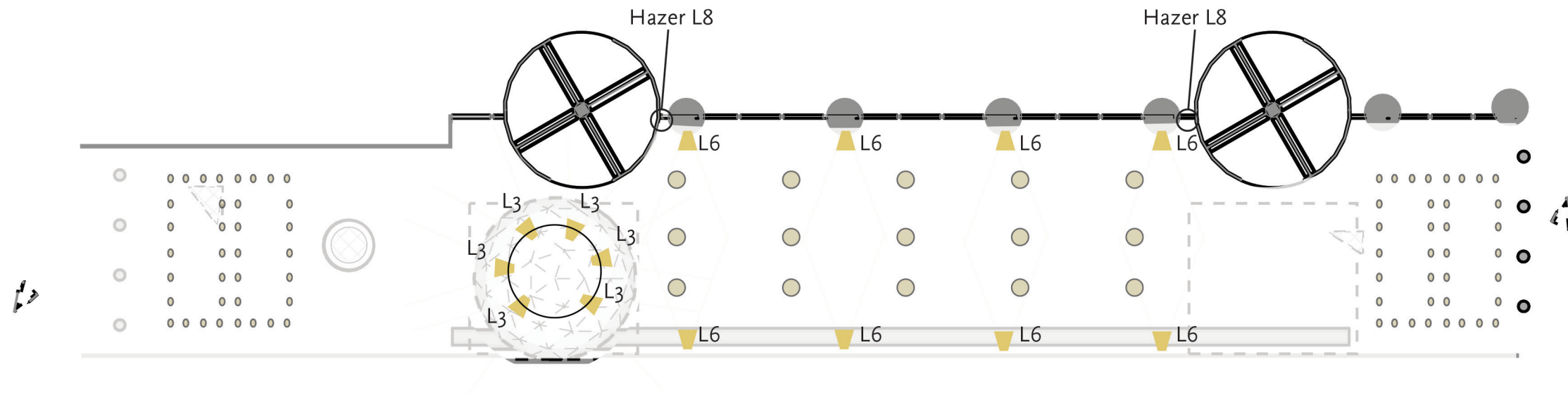

1 :: RCP Area 04
 ::Location:: James M. Nederlander Alley 46th st. Side of Marriott Marquis btw Broadway & 8th Ave. 10036
 scale: 1/16 = 1'

Eve Frudakis
 Exhibition and Experience Design

EXHIBITION DOCUMENTATION

Fashion Institute of Technology
 School of Graduate Studies
 272 West 27th St.
 New York, NY 10011

Project:

CATALYST
 Made of Stars

Client:



DISCLAIMER

This is an unpublished and proprietary work simultaneously protected under copyright, trade secret, and like laws of the United States and other countries. All rights reserved. These materials may not be reproduced, displayed, distributed, nor may be the information therein be used or disclosed in whole or in part, without the express written permission of Eve Frudakis.

Key Plan:



Title:

RCP 04A

Scale:

1/16 = 1'

Drawn by: Eve Frudakis

Date: 11.03.2021



EX 325

Drawing NO.

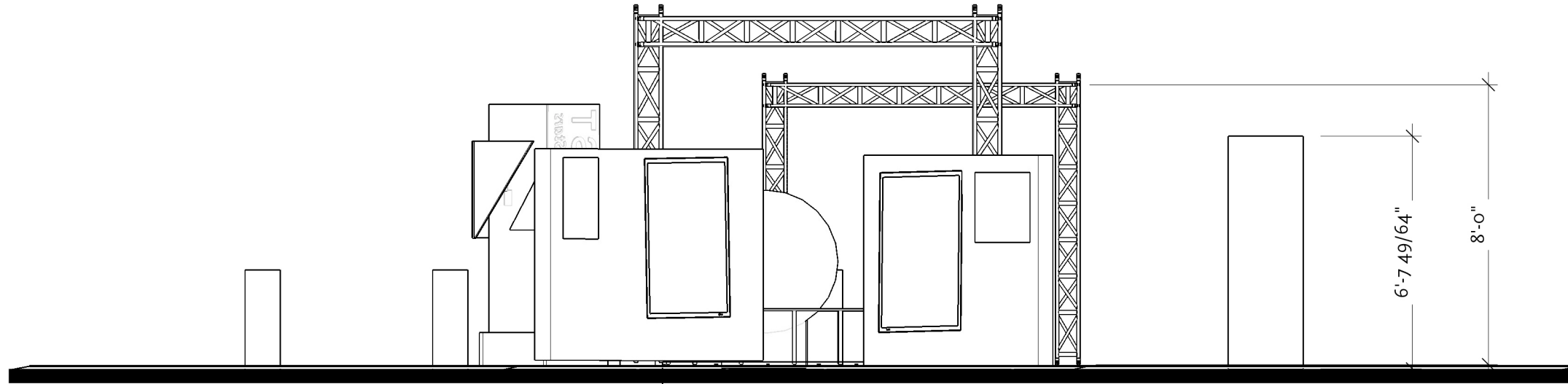

1 :: Elevation Section 01A
 scale: 1/4" = 1'

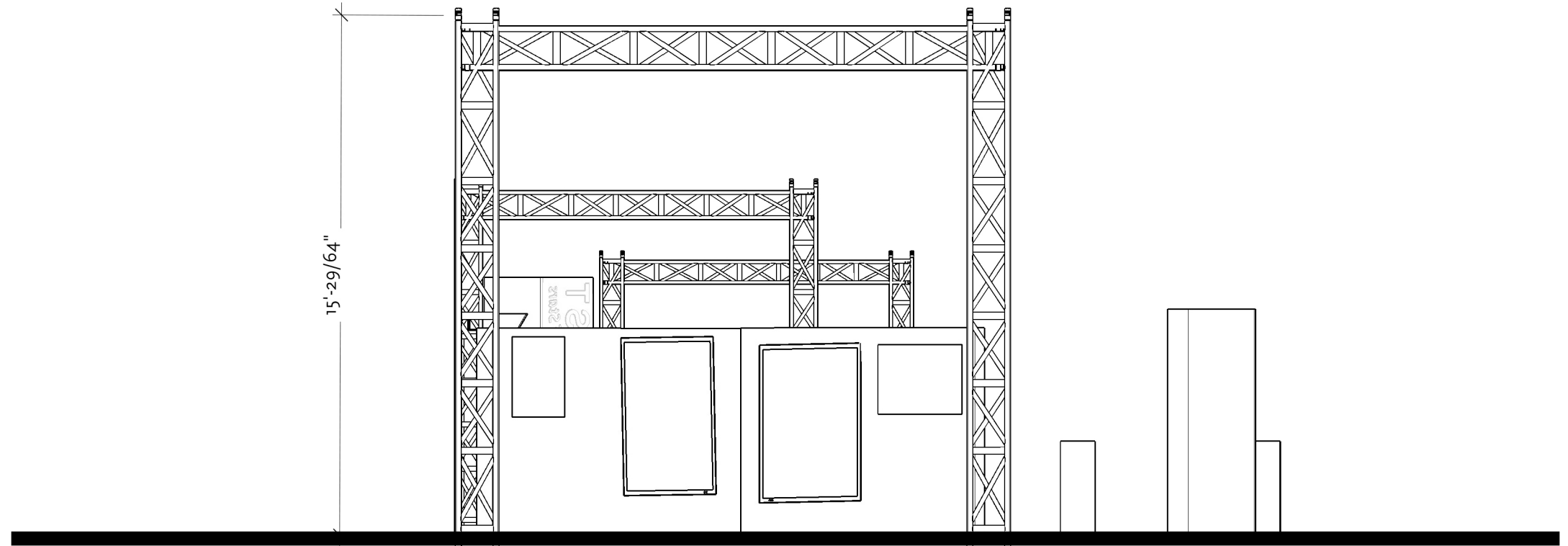

2 :: Elevation Section 01A
 scale: 1/4" = 1'

Eve Frudakis
 Exhibition and Experience Design
 EXHIBITION DOCUMENTATION

Fashion Institute of Technology
 School of Graduate Studies
 272 West 27th St.
 New York, NY 10011

Project:
CATALYST
 Made of Stars

Client:
 AMERICAN MUSEUM
 & NATURAL HISTORY

DISCLAIMER
 This is an unpublished and proprietary work simultaneously protected under copyright, trade secret, and like laws of the United States and other countries. All rights reserved. These materials may not be reproduced, displayed, distributed, nor may be the information therein be used or disclosed in whole or in part, without the express written permission of Eve Frudakis.

Key Plan:

Title:
 01A Sections 1 and 2

Scale:
 1/4" = 1'
 Drawn by: Eve Frudakis
 Date: 11.03.2021

EX 326
 Drawing NO.

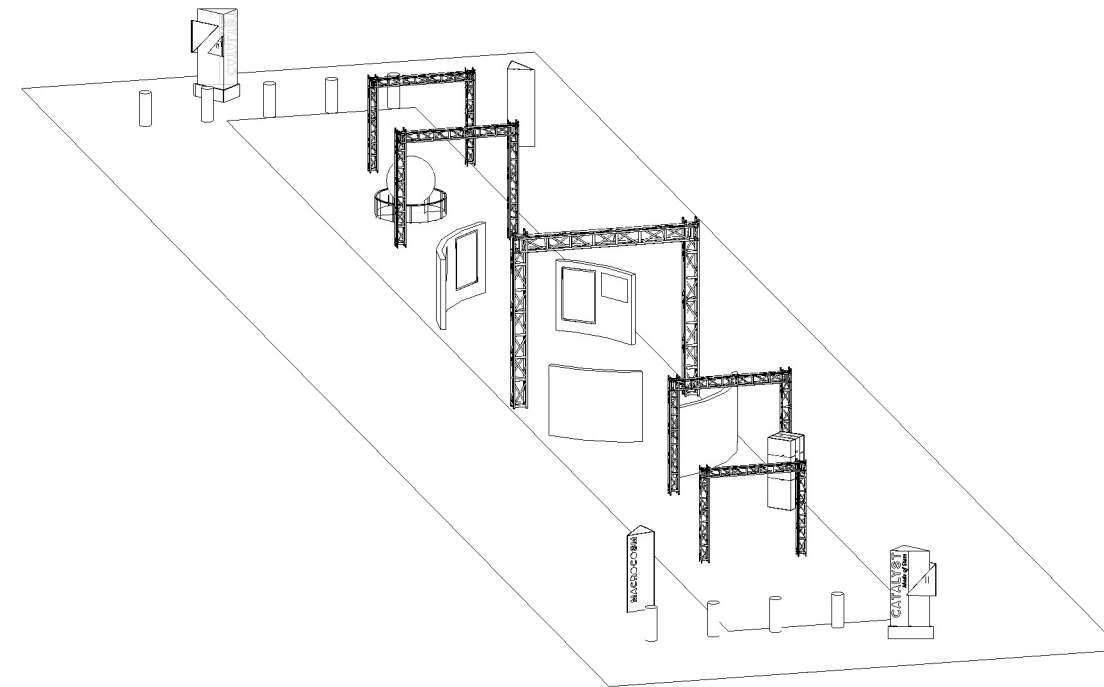

01A :: AXO View Reference
 ○ scale: N/A

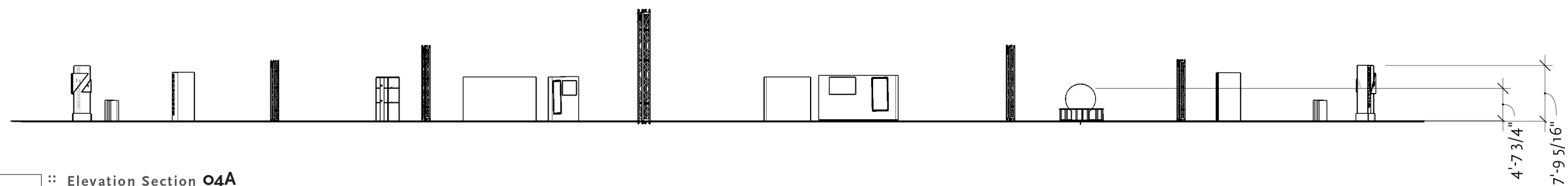

1 :: Elevation Section 04A
 scale: 1/16" = 1'

4'-7 3/4"
 7'-9 5/16"

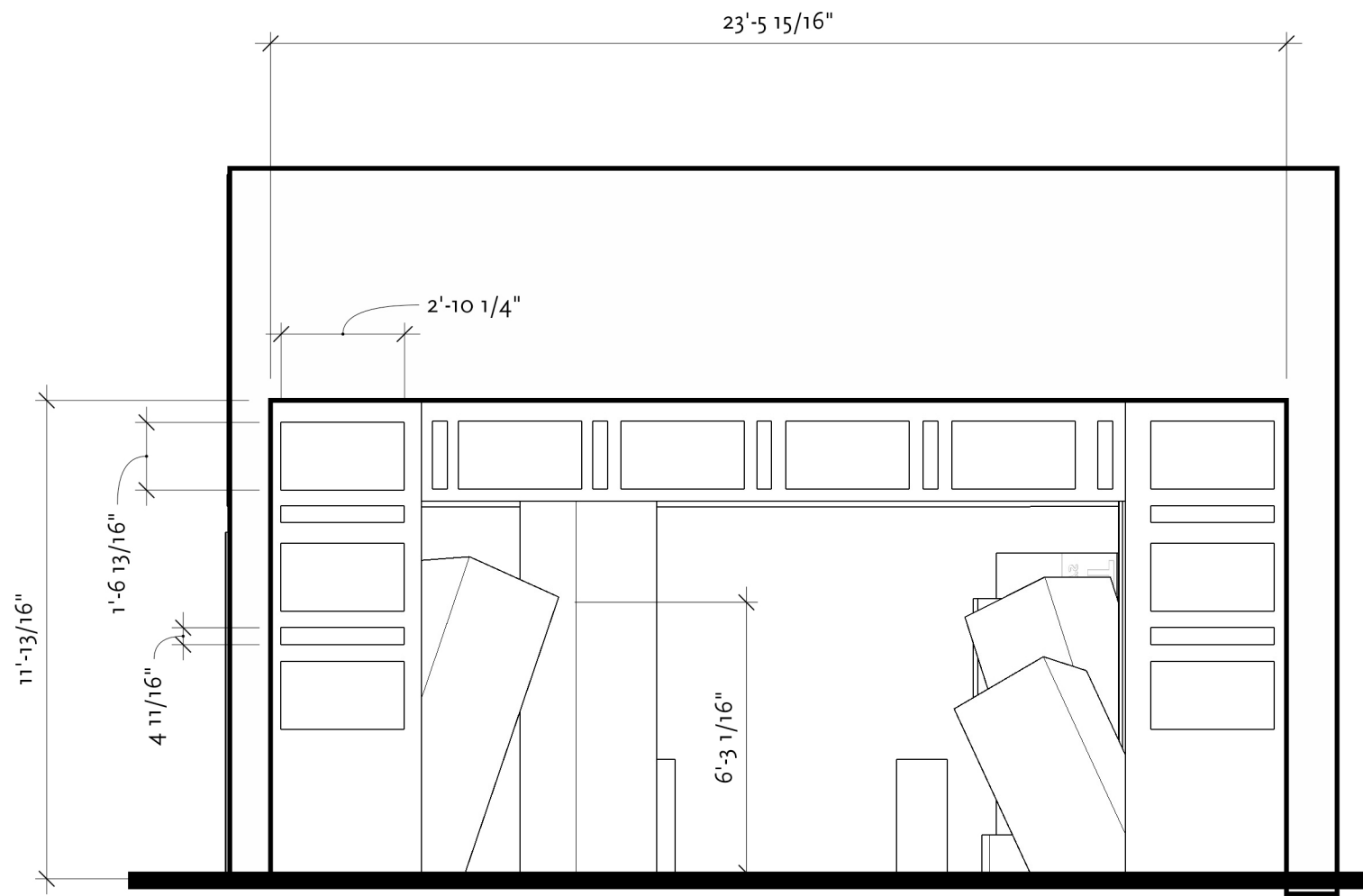

<p>Eve Frudakis <i>Exhibition and Experience Design</i></p> <p>EXHIBITION DOCUMENTATION</p>	<p>Fashion Institute of Technology <i>School of Graduate Studies</i> 272 West 27th St. New York, NY 10011</p>	<p>Project:</p> <p>CATALYST <i>Made of Stars</i></p>	<p>Client:</p> <p> AMERICAN MUSEUM OF NATURAL HISTORY</p>	<p>DISCLAIMER This is an unpublished and proprietary work simultaneously protected under copyright, trade secret, and like laws of the United States and other countries. All rights reserved. These materials may not be reproduced, displayed, distributed, nor may be the information therein be used or disclosed in whole or in part, without the express written permission of Eve Frudakis.</p>	<p>Key Plan:</p>	<p>Title: <i>Area 01A Section 3</i></p>	<p>Scale: 1/16" = 1'</p> <p>Drawn by: <i>Eve Frudakis</i></p> <p>Date: 11.03.2021</p>	<p> EX 327</p> <p>Drawing NO.</p>
--	---	--	---	--	------------------	--	--	--

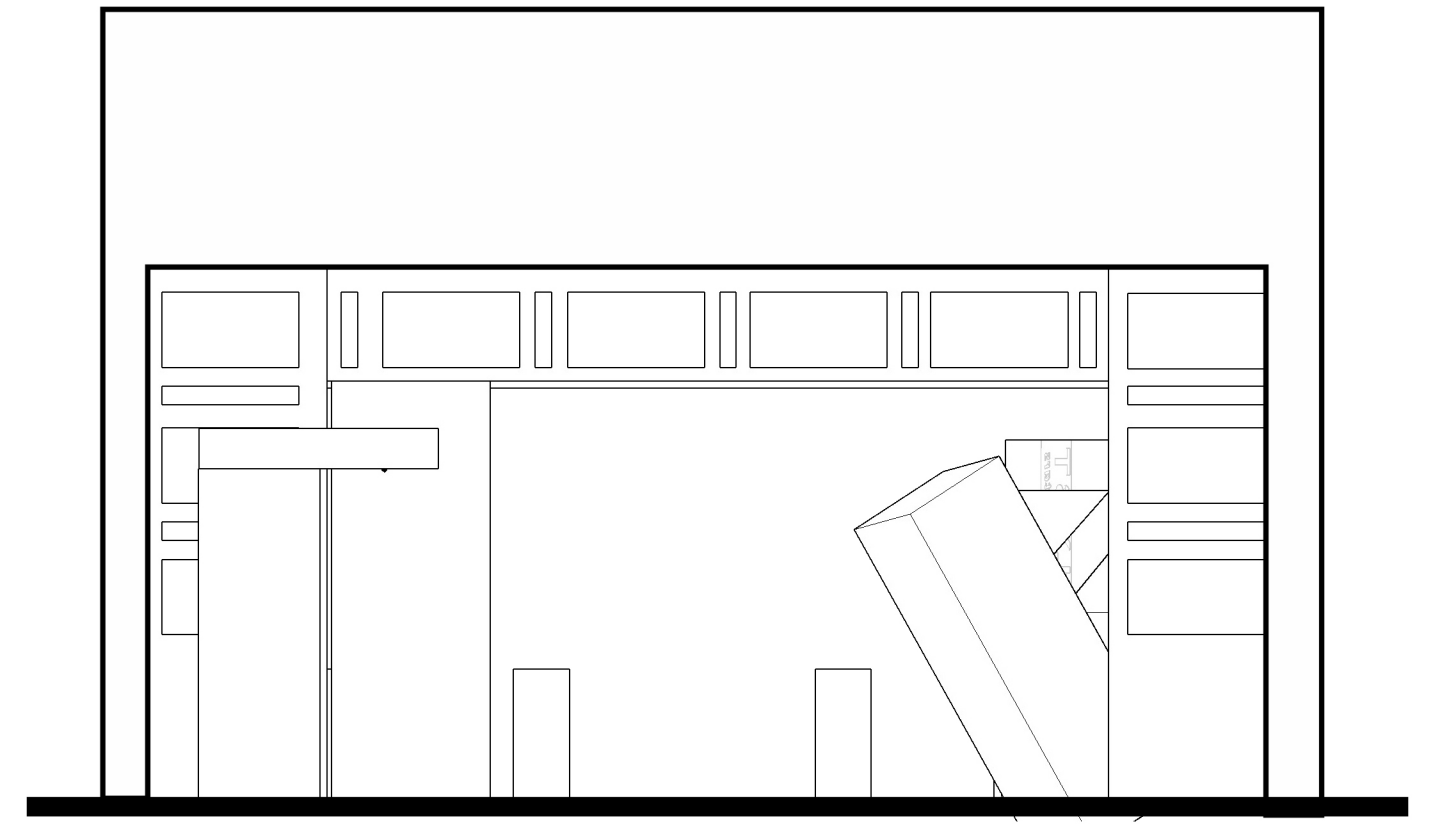

1 :: Elevation Section **02A**
 scale: 1/4" = 1'

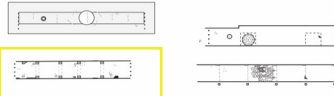

2 :: Elevation Section **02A**
 scale: 1/4" = 1'

<p>Eve Frudakis <i>Exhibition and Experience Design</i></p> <hr/> <p>EXHIBITION DOCUMENTATION</p>	<p>Fashion Institute of Technology <i>School of Graduate Studies</i> 272 West 27th St. New York, NY 10011</p>	<p>Project:</p> <div style="border: 2px solid black; padding: 5px; display: inline-block;"> <p>CATALYST <i>Made of Stars</i></p> </div>	<p>Client:</p>  <p>AMERICAN MUSEUM & NATURAL HISTORY</p>	<p>DISCLAIMER This is an unpublished and proprietary work simultaneously protected under copyright, trade secret, and like laws of the United States and other countries. All rights reserved. These materials may not be reproduced, displayed, distributed, nor may be the information therein be used or disclosed in whole or in part, without the express written permission of Eve Frudakis.</p>	<p>Key Plan:</p> 	<p>Title: 02A Section 1 and 2</p>	<p>Scale: 1/4" = 1'</p> <p>Drawn by: <i>Eve Frudakis</i></p> <p>Date: 11.03.2021</p>	<div style="border: 1px solid black; padding: 5px; display: inline-block;">  <p>EX 328</p> </div> <p>Drawing NO.</p>
--	---	---	--	--	--	---	---	--

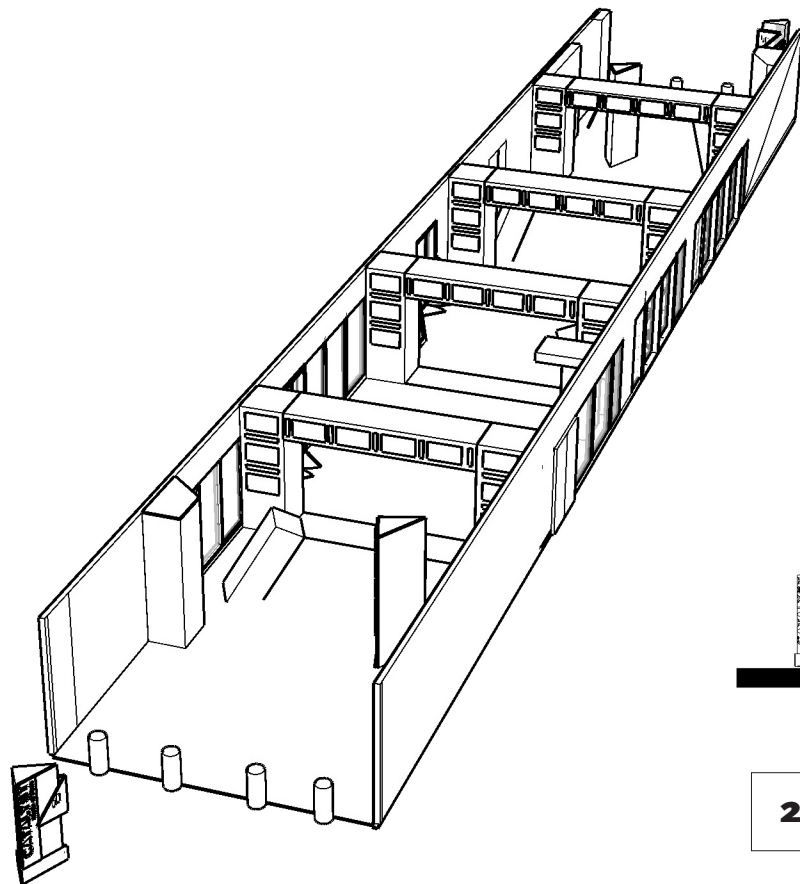

1 :: Axo Reference 02A
scale: N/A

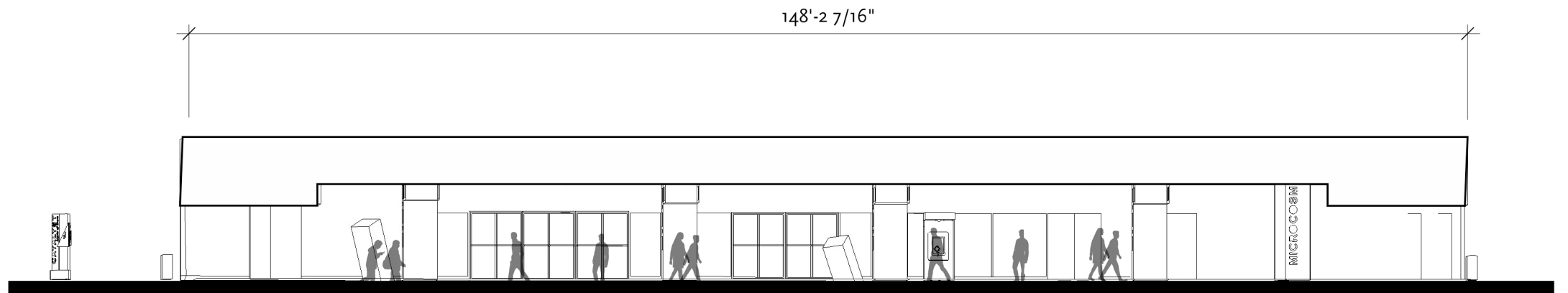

2 :: Elevation Section 02A
scale: 1/16 = 1'

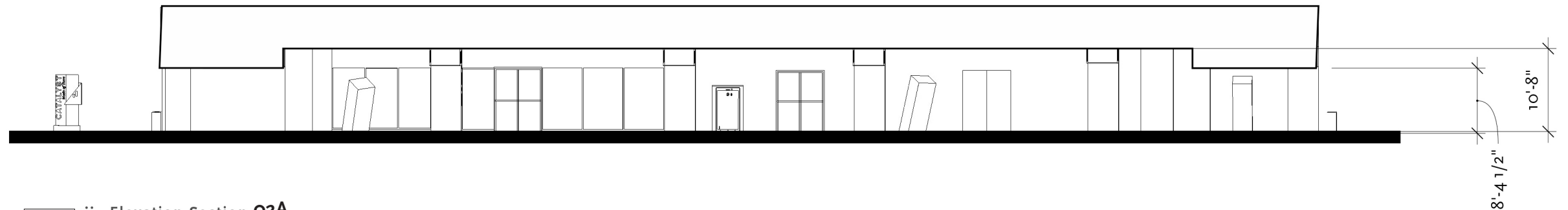

3 :: Elevation Section 02A
scale: 1/16 = 1'

Eve Frudakis
Exhibition and Experience Design

EXHIBITION DOCUMENTATION

Fashion Institute of Technology
School of Graduate Studies
272 West 27th St.
New York, NY 10011

Project:

CATALYST
Made of Stars

Client:



DISCLAIMER

This is an unpublished and proprietary work simultaneously protected under copyright, trade secret, and like laws of the United States and other countries. All rights reserved. These materials may not be reproduced, displayed, distributed, nor may be the information therein be used or disclosed in whole or in part, without the express written permission of Eve Frudakis.

Key Plan:

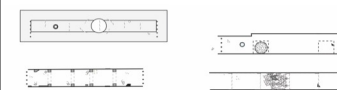

Title:

02A Sections 3 and 4

Scale:

1/16 = 1'

Drawn by: Eve Frudakis

Date: 11.03.2021



EX 329



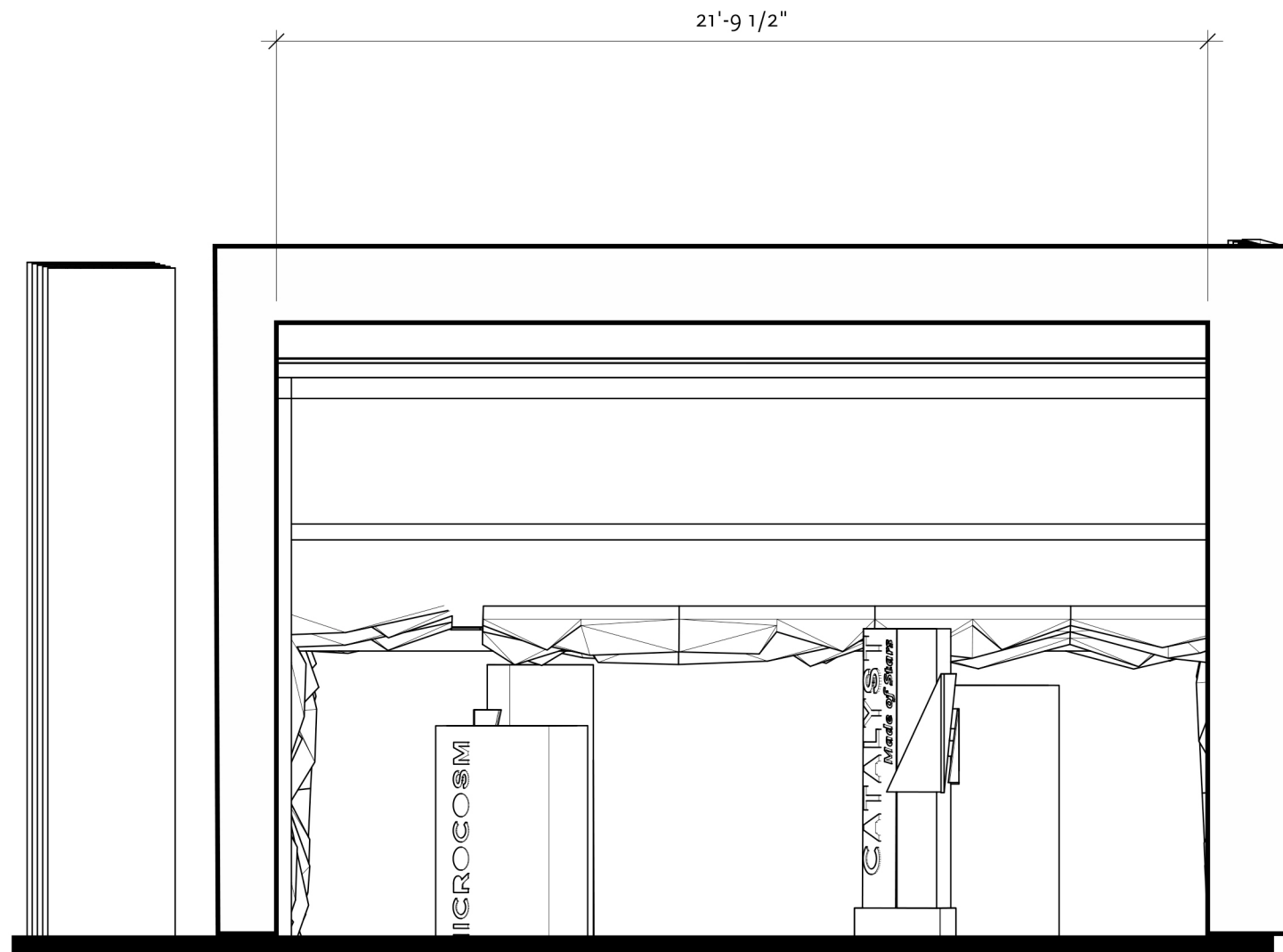

Drawing NO.

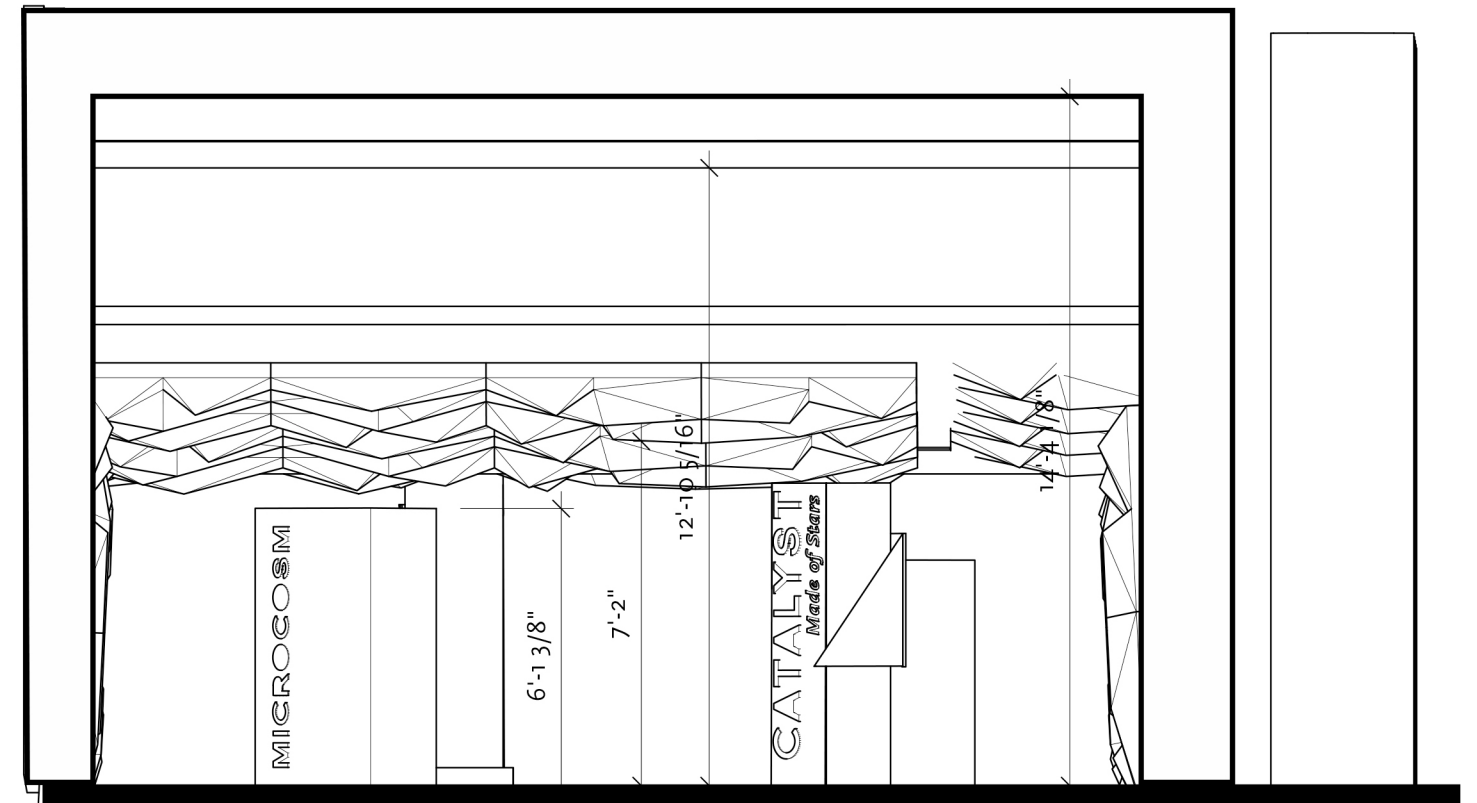

1 :: Elevation Section 03A
scale: 1/4 = 1'

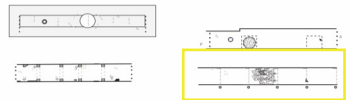

2 :: Elevation Section 03A
scale: 1/4 = 1'

Eve Frudakis <i>Exhibition and Experience Design</i> EXHIBITION DOCUMENTATION	Fashion Institute of Technology School of Graduate Studies 272 West 27th St. New York, NY 10011	Project: 	Client: 	DISCLAIMER This is an unpublished and proprietary work simultaneously protected under copyright, trade secret, and like laws of the United States and other countries. All rights reserved. These materials may not be reproduced, displayed, distributed, nor may be the information therein be used or disclosed in whole or in part, without the express written permission of Eve Frudakis.	Key Plan: 	Title: 03A Sections 1 and 2	Scale: 1/4 = 1'	 EX 330 Drawing NO.
							Drawn by: Eve Frudakis Date: 11.03.2021	

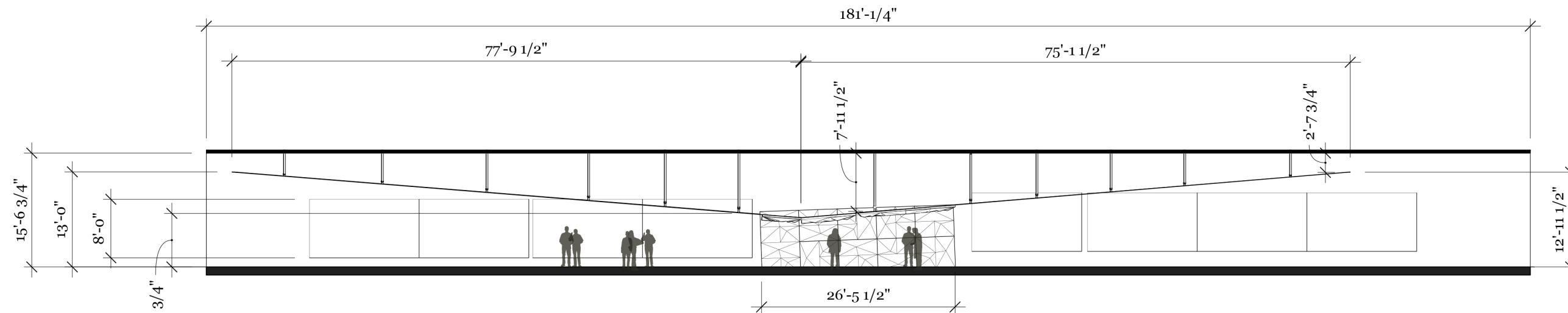

2 :: Elevation Section 03A
 scale: 1/16 = 1'

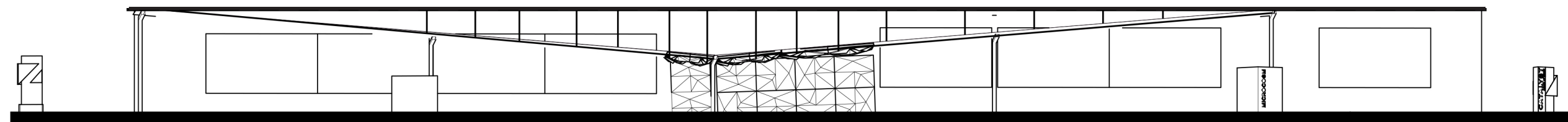

1 :: Elevation Section 03A
 scale: 1/16 = 1'



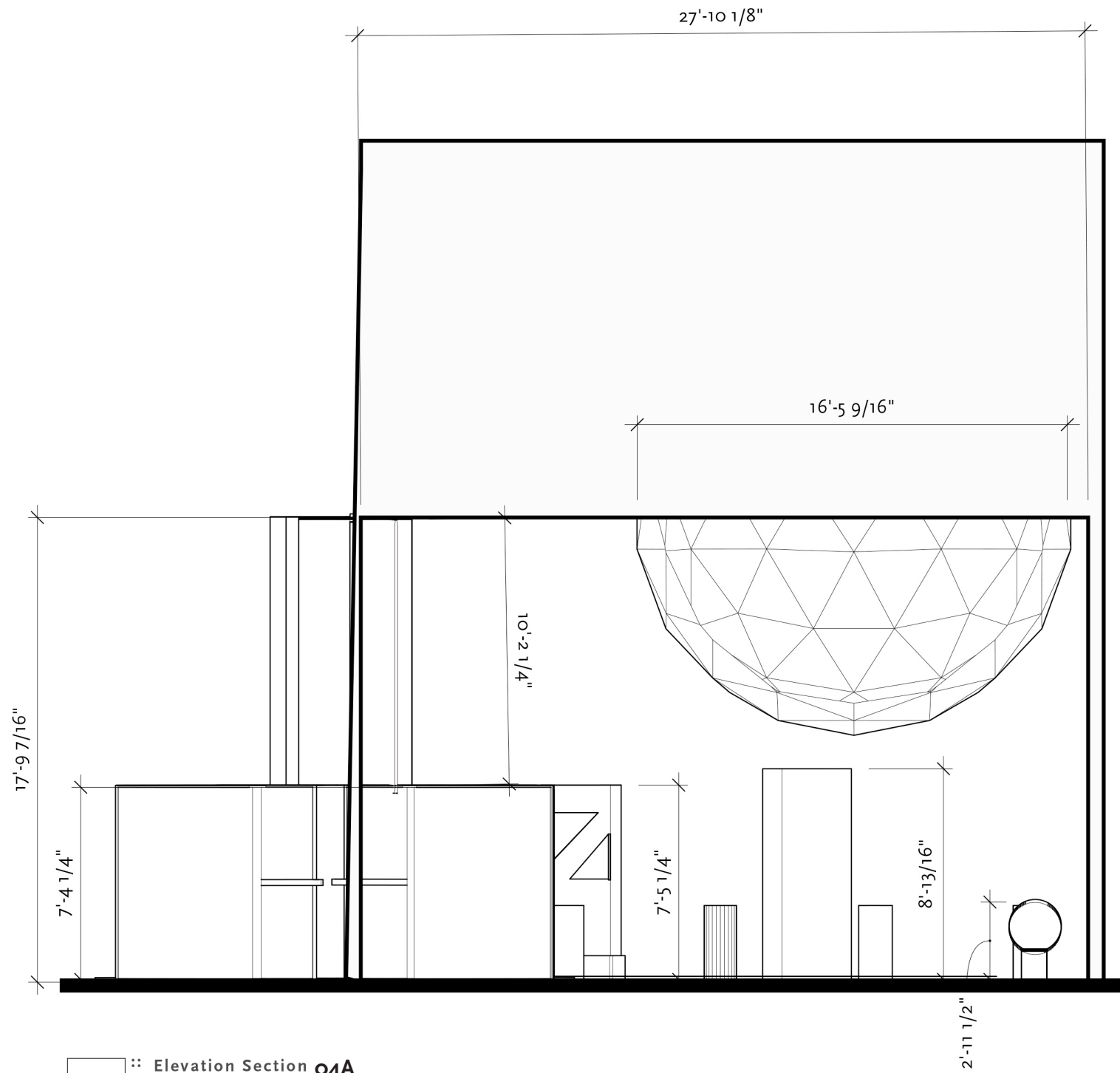

Eve Frudakis <i>Exhibition and Experience Design</i> EXHIBITION DOCUMENTATION	Fashion Institute of Technology <i>School of Graduate Studies</i> 272 West 27th St. New York, NY 10011	Project: 	Client: 	DISCLAIMER This is an unpublished and proprietary work simultaneously protected under copyright, trade secret, and like laws of the United States and other countries. All rights reserved. These materials may not be reproduced, displayed, distributed, nor may be the information therein be used or disclosed in whole or in part, without the express written permission of Eve Frudakis.	Key Plan: 	Title: 03A Sections 3 and 4	Scale: 1/16 = 1'	EX 331 Drawing NO.
							Drawn by: <i>Eve Frudakis</i> Date: 11.03.2021	

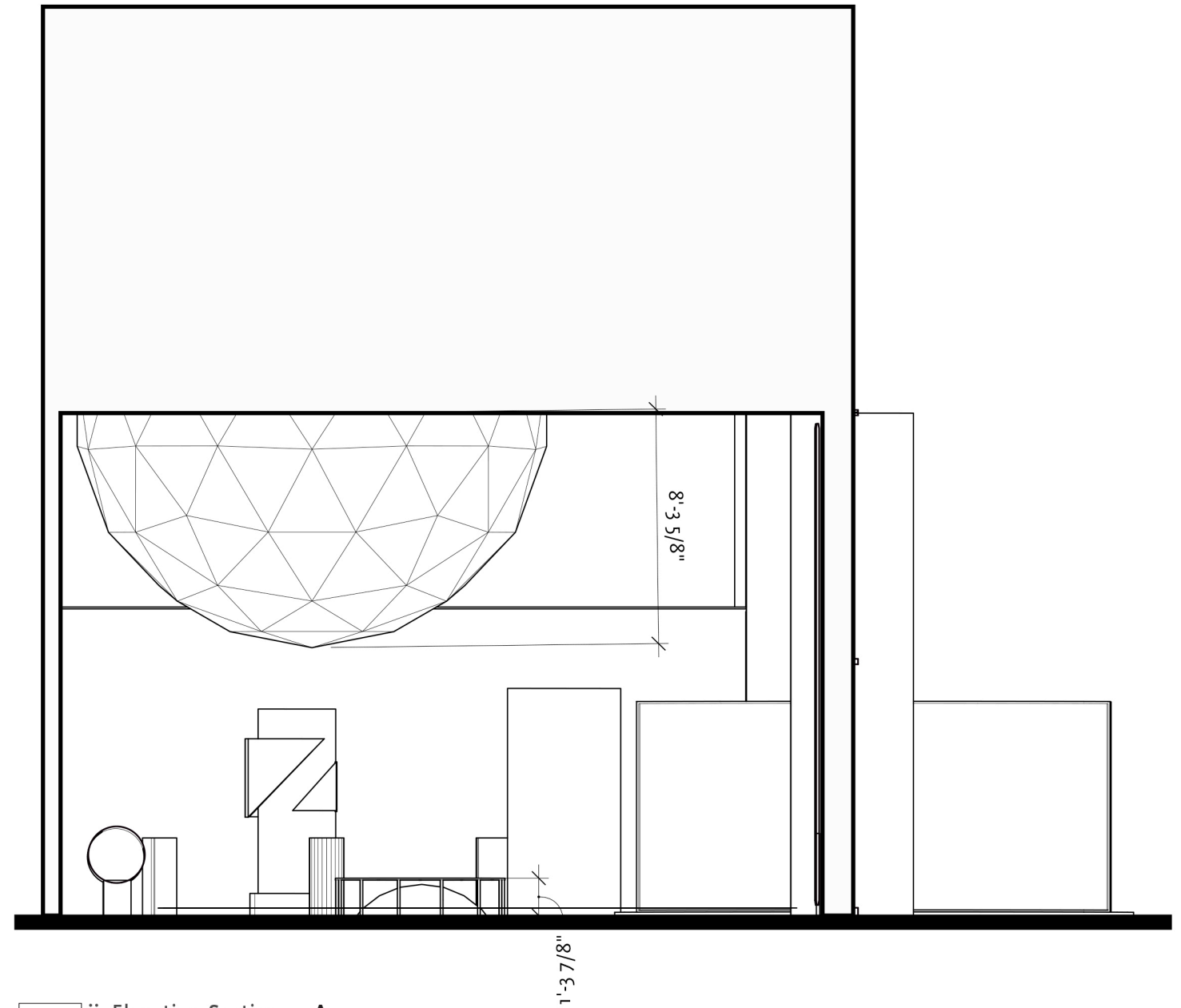

1 :: Elevation Section 04A
scale: 3/16 = 1'

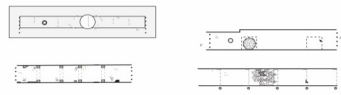

2 :: Elevation Section 04A
scale: 3/16 = 1'

Eve Frudakis <i>Exhibition and Experience Design</i>	Fashion Institute of Technology <i>School of Graduate Studies</i> 272 West 27th St. New York, NY 10011	Project: 	Client: 	DISCLAIMER <small>This is an unpublished and proprietary work simultaneously protected under copyright, trade secret, and like laws of the United States and other countries. All rights reserved. These materials may not be reproduced, displayed, distributed, nor may be the information therein be used or disclosed in whole or in part, without the express written permission of Eve Frudakis.</small>	Key Plan: 	Title: <i>04A Sections 1 and 2</i>	Scale: 3/16 = 1'	 EX 332 Drawing NO.
	EXHIBITION DOCUMENTATION	Drawn by: <i>Eve Frudakis</i> Date: 11.03.2021						

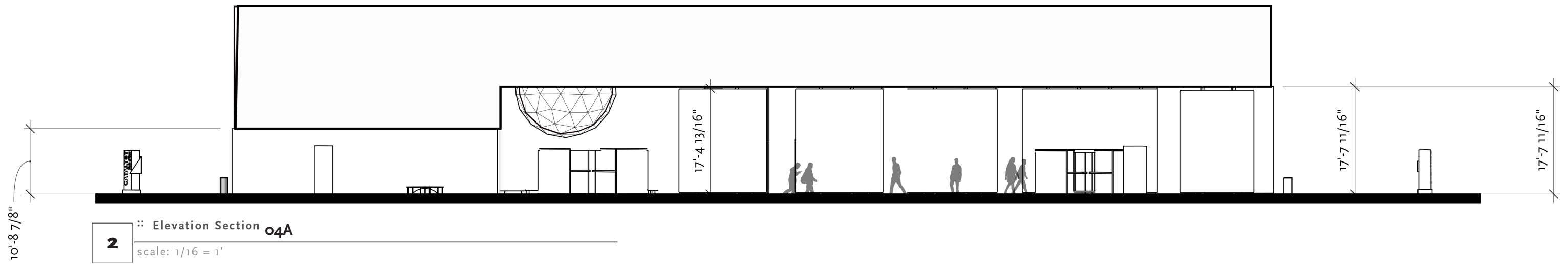

2 :: Elevation Section **04A**
 scale: 1/16 = 1'

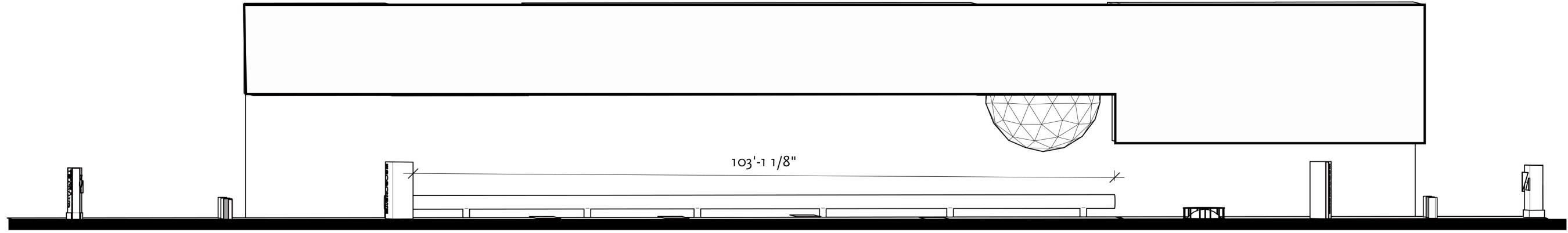

1 :: Elevation Section **04A**
 scale: 1/16 = 1'

Eve Frudakis
 Exhibition and Experience Design
 EXHIBITION DOCUMENTATION

Fashion Institute of Technology
 School of Graduate Studies
 272 West 27th St.
 New York, NY 10011

Project:
CATALYST
 Made of Stars

Client:
 AMERICAN MUSEUM
 OF NATURAL HISTORY

DISCLAIMER
 This is an unpublished and proprietary work simultaneously protected under copyright, trade secret, and like laws of the United States and other countries. All rights reserved. These materials may not be reproduced, displayed, distributed, nor may be the information therein be used or disclosed in whole or in part, without the express written permission of Eve Frudakis.

Key Plan:

Title:
 04A Sections 1 and 2

Scale:
 1/16 = 1'
 Drawn by: Eve Frudakis
 Date: 11.03.2021

EX 333
 Drawing NO.

:: GRAPHIC IDENTITY

:: GRAPHIC IDENTITY

TYPE

CATALYST

Made of Stars

AN IMMERSIVE JOURNEY OF THE INNATE...
 EXPERIENCE THE LARGE AND SMALL WORLDS THAT
 COEXIST WITHIN AND AROUND YOU.

Lorem ipsum dolor sit amet, consectetur adipiscing elit, sed diam nonummy nibham euismod tincunt ut laoreet dolore magna aliquam erat volutpat. Ut wisi enim adminl miminim veniam, quis nostrud exerci tation ullamcoper suscipit lobortis nisl ut et aliquip ex ea commodo consequat. Duis autem vel eum iriure dolor in hendre.

"Be still and listen, the earth breathes."

<small>Flourensia Black Regular</small> ABCDEFGHIJKLM NOPQRSTUVWXYZ abcdefghijklm nopqrstuvwxyz 1234567890	<small>ScalaSansOT BoldItalic</small> ABCDEFGHIJKLM NOPQRSTUVWXYZ abcdefghijklm nopqrstuvwxyz 1234567890	<small>ScalaSansOT Italic</small> ABCDEFGHIJKLM NOPQRSTUVWXYZ abcdefghijklm nopqrstuvwxyz 1234567890
<small>ScalaSansOT CondBold</small> ABCDEFGHIJKLM NOPQRSTUVWXYZ abcdefghijklm nopqrstuvwxyz 1234567890	<small>ScalaSansOT Regular</small> ABCDEFGHIJKLM NOPQRSTUVWXYZ abcdefghijklm nopqrstuvwxyz 1234567890	

REFERENCE

Patterns | Textures



Patterns A Texture A Look Reference Patterns B Texture B Texture C Pattern C

Material

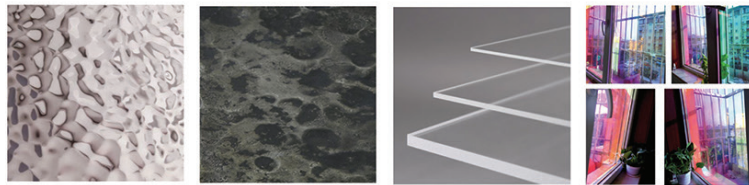

Hammered Steel W Hammered Steel BK Plexi Transparent film

Lighting

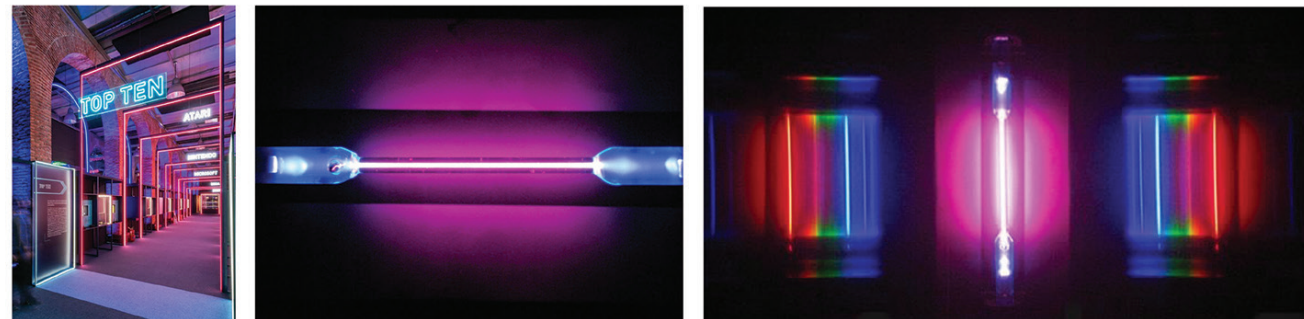

LOGO



COLOR



Eve Frudakis <i>Exhibition and Experience Design</i> EXHIBITION DOCUMENTATION	Fashion Institute of Technology <i>School of Graduate Studies</i> 272 West 27th St. New York, NY 10011	Project: 	Client: 	DISCLAIMER <small>This is an unpublished and proprietary work simultaneously protected under copyright, trade secret, and like laws of the United States and other countries. All rights reserved. These materials may not be reproduced, displayed, distributed, nor may be the information therein be used or disclosed in whole or in part, without the express written permission of Eve Frudakis.</small>	Key Plan:	Title: <i>Graphic Identity</i>	Scale: N/A	EX 400
							Drawn by: <i>Eve Frudakis</i> Date: 11.03.2021	Drawing NO.

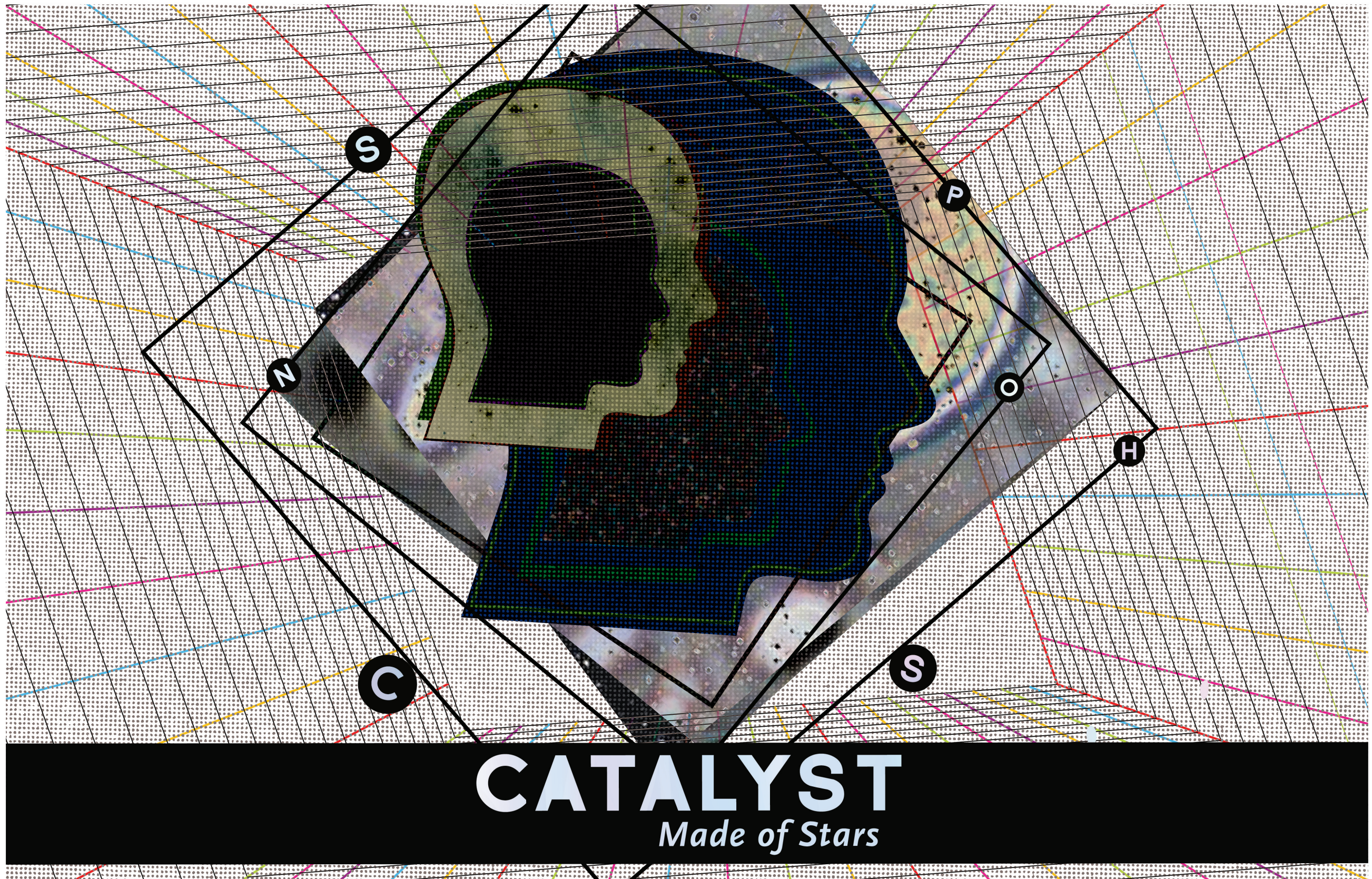

Eve Frudakis
 Exhibition and Experience Design
 EXHIBITION DOCUMENTATION

Fashion Institute of Technology
 School of Graduate Studies
 272 West 27th St.
 New York, NY 10011

Project:

Client:

DISCLAIMER
 This is an unpublished and proprietary work simultaneously protected under copyright, trade secret, and like laws of the United States and other countries. All rights reserved. These materials may not be reproduced, displayed, distributed, nor may be the information therein be used or disclosed in whole or in part, without the express written permission of Eve Frudakis.

Key Plan:

Title:
Look and Feel

Scale:
 N/A
 Drawn by: *Eve Frudakis*
 Date: 11.03.2021

EX 401
 Drawing NO.

:: AREA LOOK AND FEEL

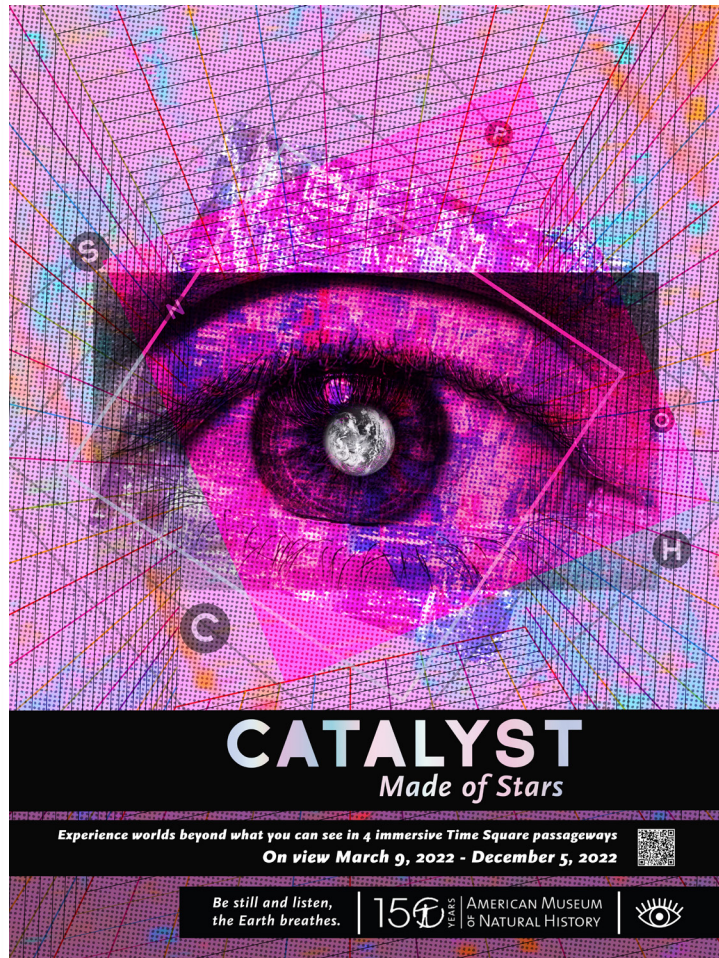

AREA 01: WHAT WE CAN SEE

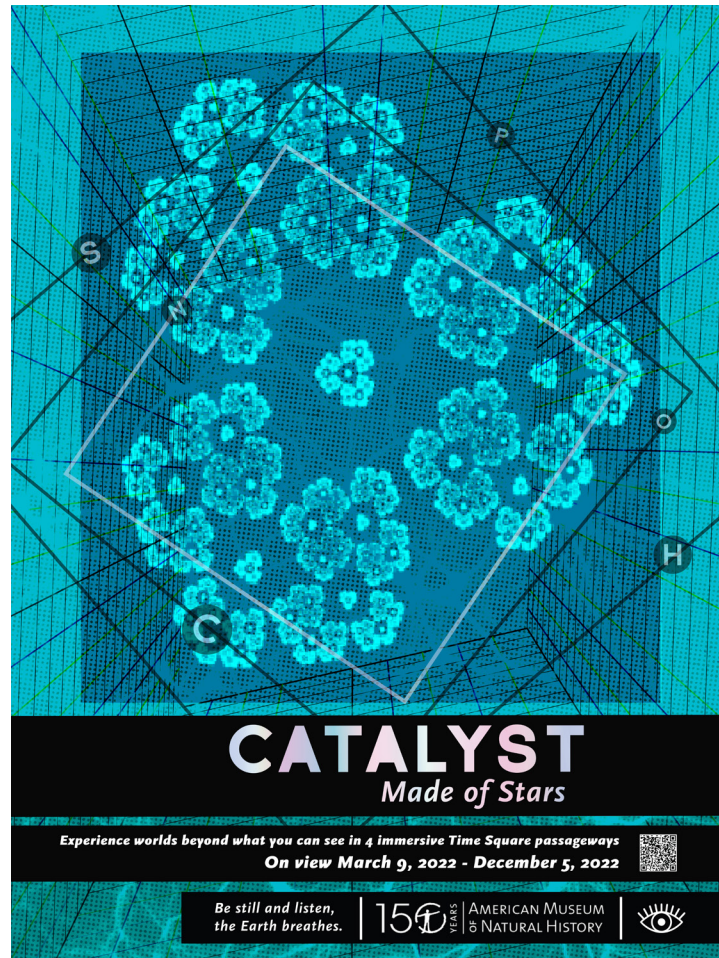

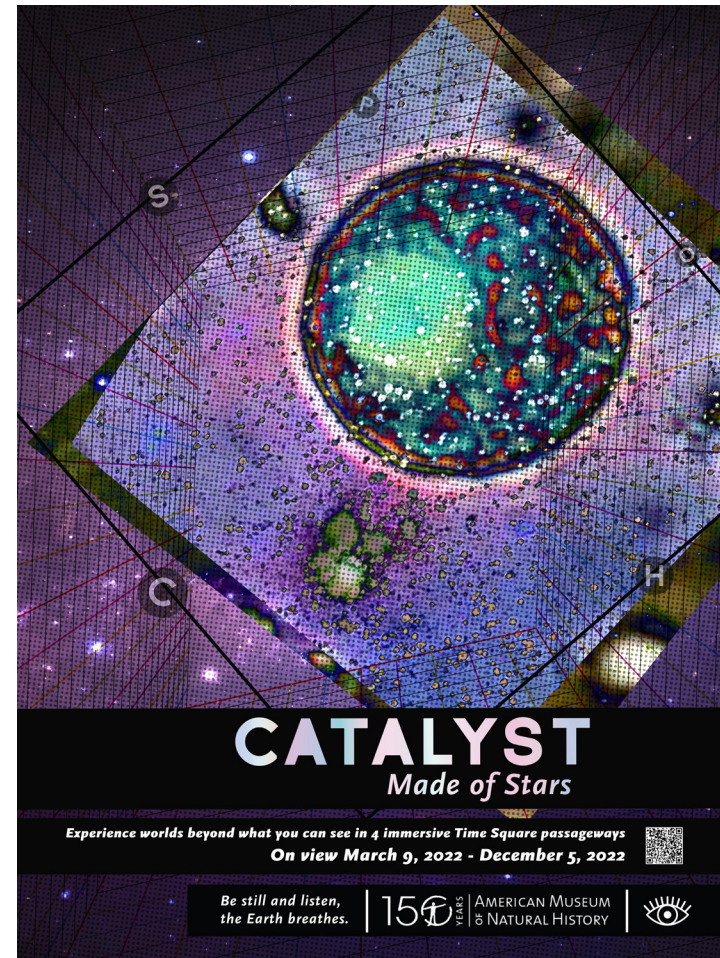

AREA 02: WHAT IS A FRACTAL?

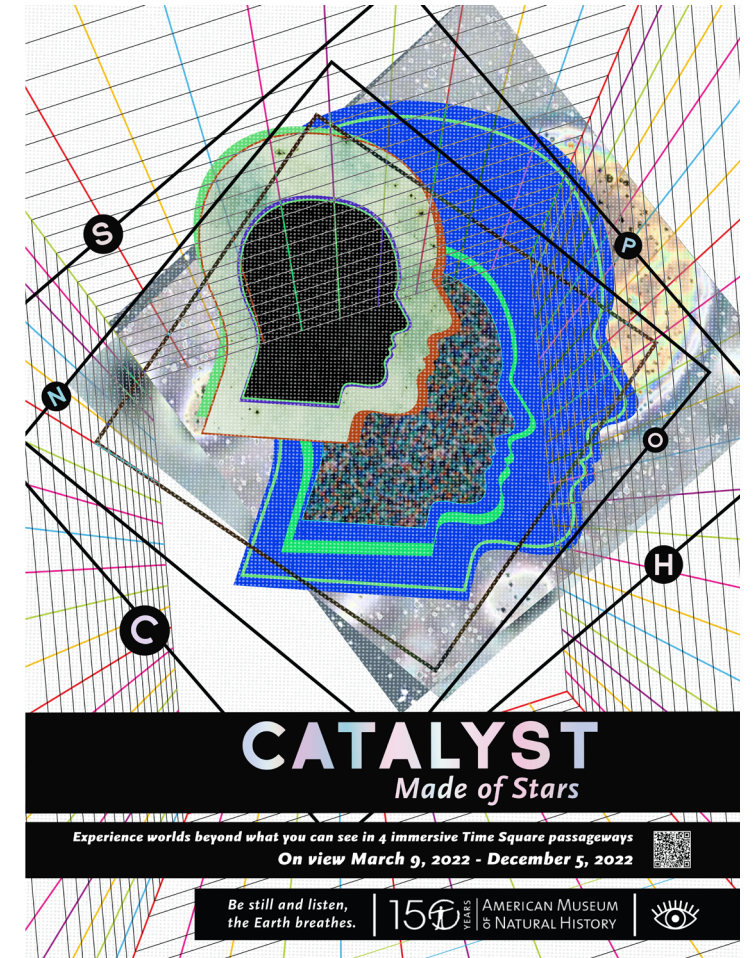

AREA 03: ATOMIC MAYHEM





AREA 04: COSMIC SCALE

<p>Eve Frudakis Exhibition and Experience Design</p> <p>EXHIBITION DOCUMENTATION</p>	<p>Fashion Institute of Technology School of Graduate Studies 272 West 27th St. New York, NY 10011</p>	<p>Project:</p> 	<p>Client:</p> 	<p>DISCLAIMER This is an unpublished and proprietary work simultaneously protected under copyright, trade secret, and like laws of the United States and other countries. All rights reserved. These materials may not be reproduced, displayed, distributed, nor may be the information therein be used or disclosed in whole or in part, without the express written permission of Eve Frudakis.</p>	<p>Key Plan:</p>	<p>Title: <i>Area Look and Feel</i></p>	<p>Scale: N/A</p> <p>Drawn by: <i>Eve Frudakis</i></p> <p>Date: <i>11.03.2021</i></p>	<p>EX 402</p> <p>Drawing NO.</p>
--	---	---	--	---	------------------	---	---	---

:: WAY-FINDING



<p>Eve Frudakis Exhibition and Experience Design</p> <hr/> <p>EXHIBITION DOCUMENTATION</p>	<p>Fashion Institute of Technology School of Graduate Studies 272 West 27th St. New York, NY 10011</p>	<p>Project:</p> 	<p>Client:</p> 	<p>DISCLAIMER This is an unpublished and proprietary work simultaneously protected under copyright, trade secret, and like laws of the United States and other countries. All rights reserved. These materials may not be reproduced, displayed, distributed, nor may be the information therein be used or disclosed in whole or in part, without the express written permission of Eve Frudakis.</p>	<p>Key Plan:</p>	<p>Title: <i>Way-finding</i></p>	<p>Scale:</p> <hr/> <p>Drawn by: <i>Eve Frudakis</i></p> <hr/> <p>Date: 11.03.2021</p>	<p>EX 303</p> <hr/> <p>Drawing NO.</p>
--	---	---	--	---	------------------	--------------------------------------	--	---

:: WAY-FINDING

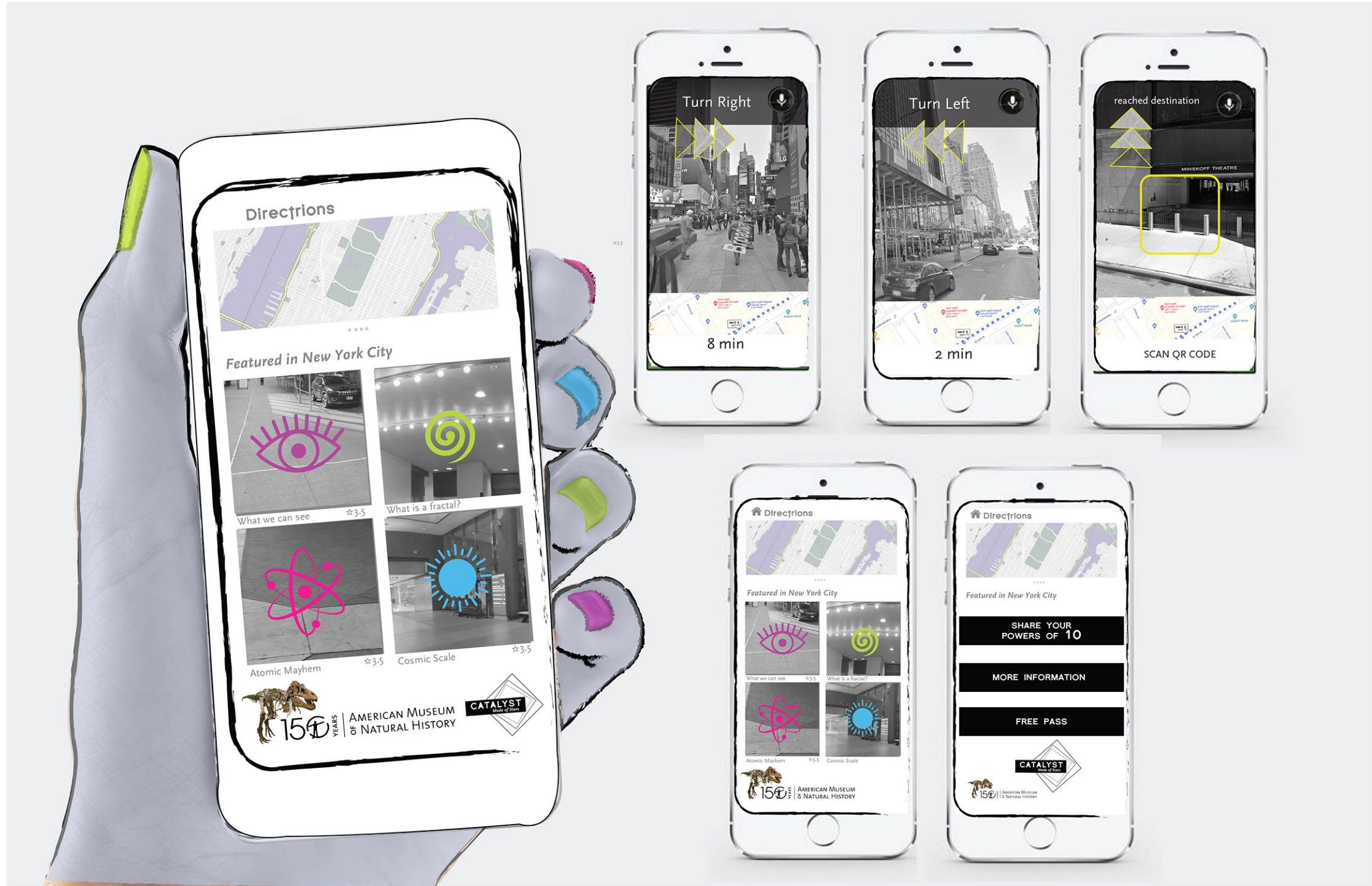

Eve Frudakis
Exhibition and Experience Design

EXHIBITION DOCUMENTATION

Fashion Institute of Technology
School of Graduate Studies
272 West 27th St.
New York, NY 10011

Project:

CATALYST
Made of Stars

Client:

 AMERICAN MUSEUM
OF NATURAL HISTORY

DISCLAIMER

This is an unpublished and proprietary work simultaneously protected under copyright, trade secret, and like laws of the United States and other countries. All rights reserved. These materials may not be reproduced, displayed, distributed, nor may be the information therein be used or disclosed in whole or in part, without the express written permission of Eve Frudakis.

Key Plan:

Title:

Way-finding

Scale:

N/A

Drawn by: Eve Frudakis



Date: 11.03.2021

EX 404

Drawing NO.

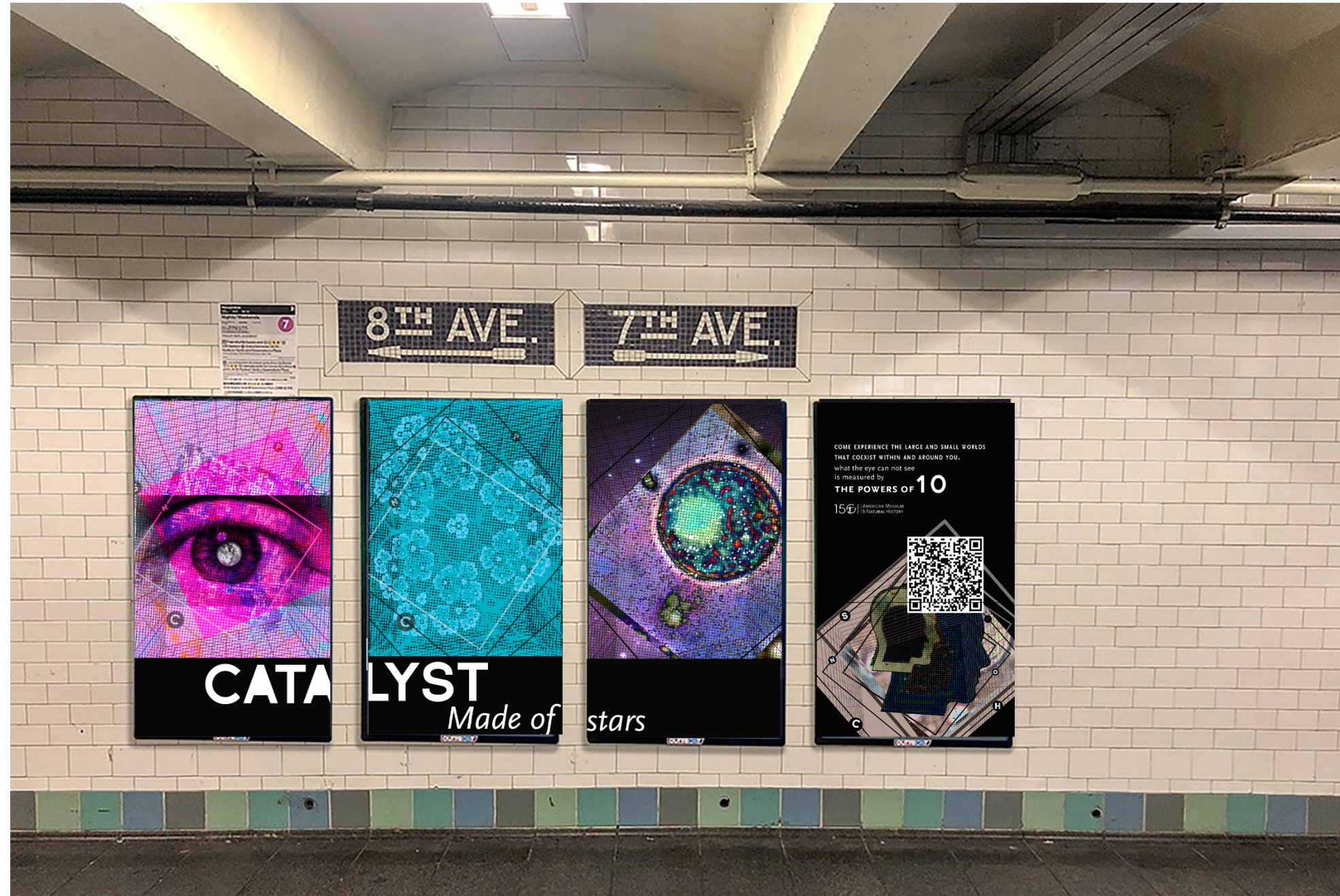
:: WAY-FINDING



<p>Eve Frudakis Exhibition and Experience Design</p>	<p>Fashion Institute of Technology School of Graduate Studies 272 West 27th St. New York, NY 10011</p>	<p>Project:</p> 	<p>Client:</p> 	<p>DISCLAIMER This is an unpublished and proprietary work simultaneously protected under copyright, trade secret, and like laws of the United States and other countries. All rights reserved. These materials may not be reproduced, displayed, distributed, nor may be the information therein be used or disclosed in whole or in part, without the express written permission of Eve Frudakis.</p>	<p>Key Plan:</p>	<p>Title: <i>Way-finding</i></p>	<p>Scale: N/A</p> <p>Drawn by: <i>Eve Frudakis</i></p> <p>Date: 11.03.2021</p>	<p>EX 405</p> <p>Drawing NO.</p>
---	---	---	--	---	------------------	--------------------------------------	--	---

:: COLLATERAL

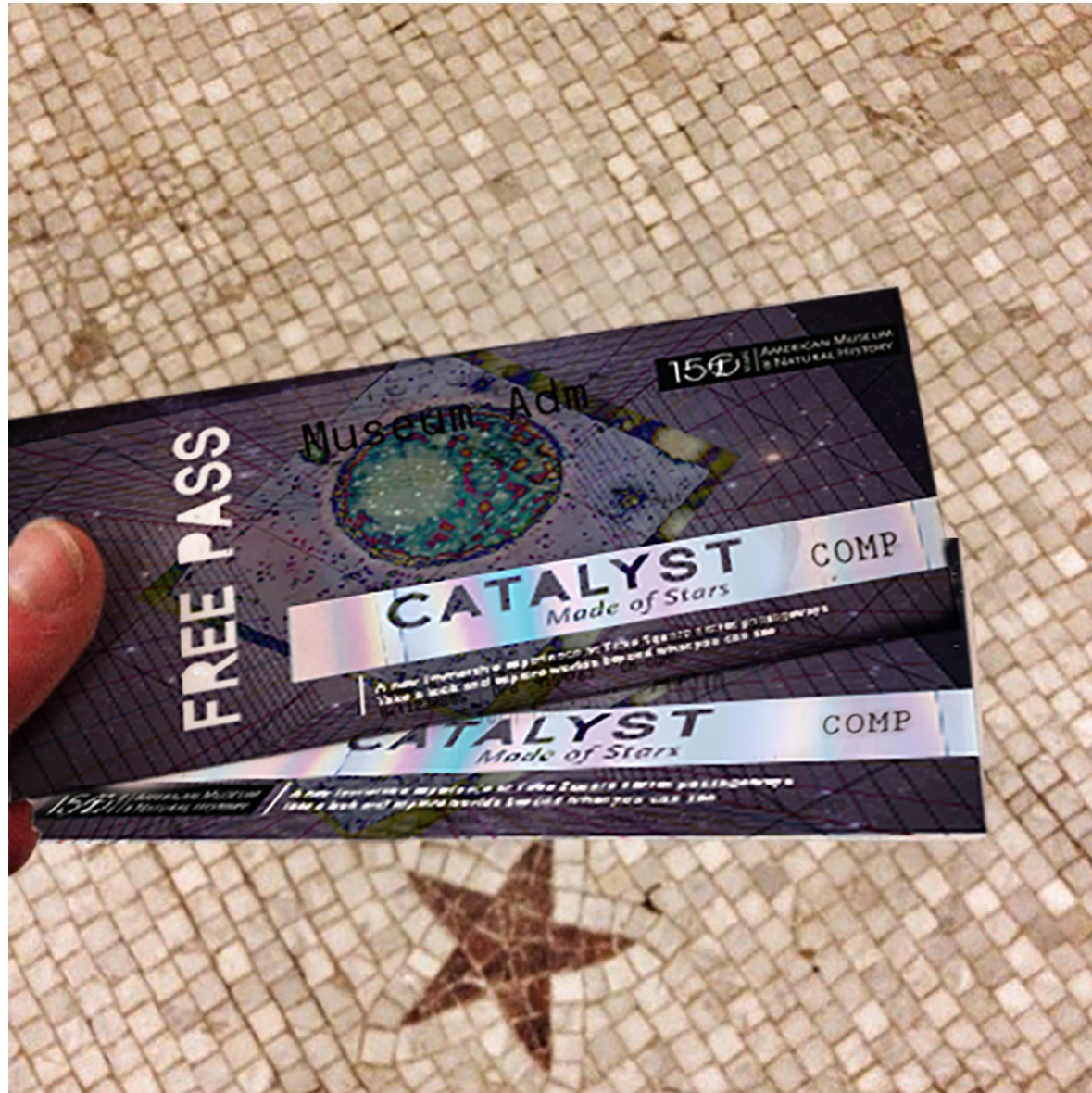

PASSES UPON CHECK IN AT AMNH w/ DIGITAL PASS



KALEIDOSCOPE



FIDGET CUBE



PRISM

<p>Eve Frudakis Exhibition and Experience Design</p> <p>EXHIBITION DOCUMENTATION</p>	<p>Fashion Institute of Technology School of Graduate Studies 272 West 27th St. New York, NY 10011</p>	<p>Project:</p> <p>CATALYST Made of Stars</p>	<p>Client:</p> <p> AMERICAN MUSEUM OF NATURAL HISTORY</p>	<p>DISCLAIMER This is an unpublished and proprietary work simultaneously protected under copyright, trade secret, and like laws of the United States and other countries. All rights reserved. These materials may not be reproduced, displayed, distributed, nor may be the information therein be used or disclosed in whole or in part, without the express written permission of Eve Frudakis.</p>	<p>Key Plan:</p>	<p>Title: <i>Collateral</i></p>	<p>Scale: N/A</p> <p>Drawn by: <i>Eve Frudakis</i></p> <p>Date: <i>11.03.2021</i></p>	<p>EX 406</p> <p>Drawing NO.</p>
--	---	--	---	---	------------------	-------------------------------------	---	---

:: EXHIBITION DETAILING

:: 00.01.GR01 | Introduction | Sign Type A & B

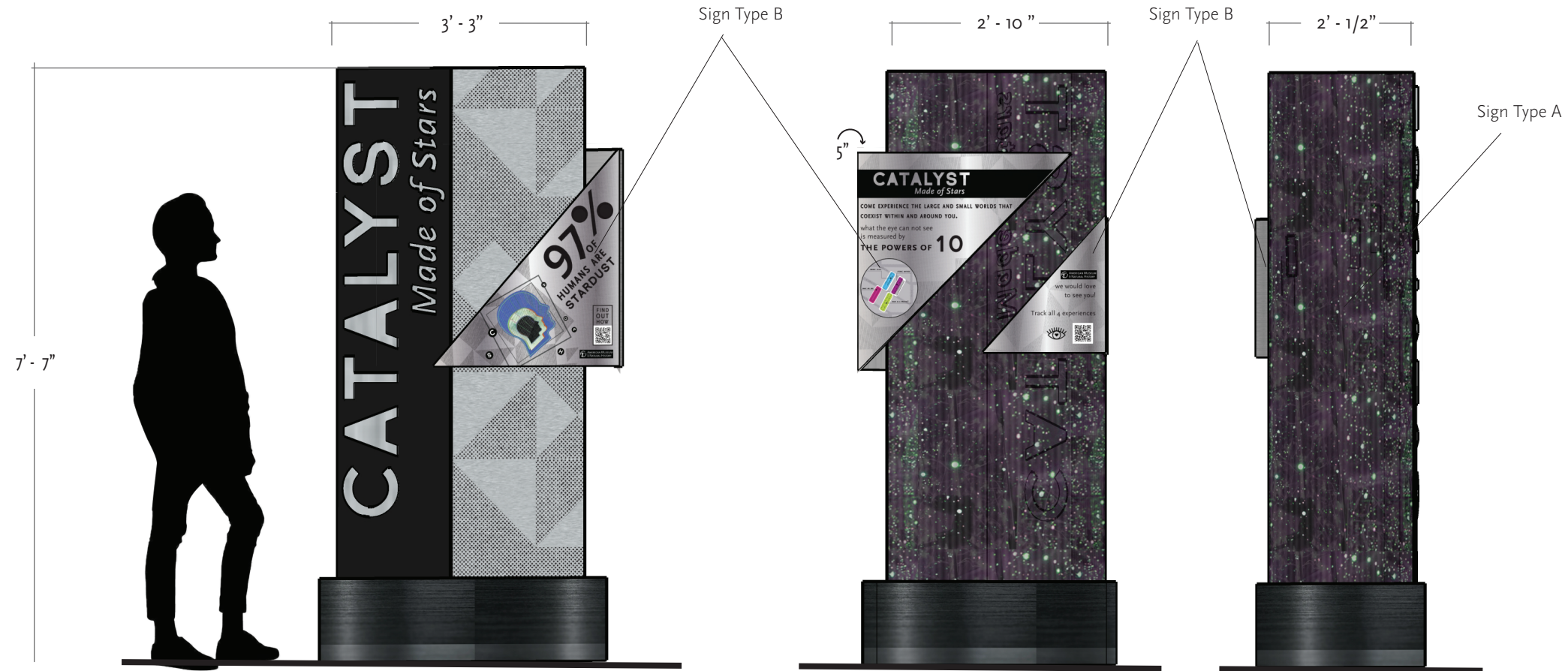

1 :: 00A.01.GR01 Side "A"
Scale: N/A

2 :: 00A.01.GR01 Side "B"
Scale: N/A

3 :: 00A.01.GR01 Side "C"
Scale: N/A

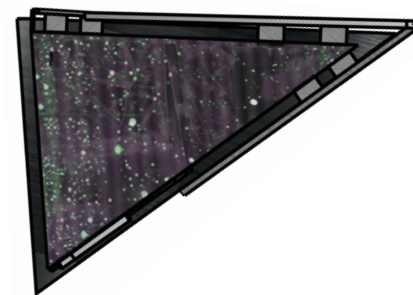

4 :: 00A.01.GR01 TOP
Scale: N/A

Eve Frudakis <i>Exhibition and Experience Design</i> EXHIBITION DOCUMENTATION	Fashion Institute of Technology <i>School of Graduate Studies</i> 272 West 27th St. New York, NY 10011	Project: 	Client: 	DISCLAIMER This is an unpublished and proprietary work simultaneously protected under copyright, trade secret, and like laws of the United States and other countries. All rights reserved. These materials may not be reproduced, displayed, distributed, nor may be the information therein be used or disclosed in whole or in part, without the express written permission of Eve Frudakis.	Key Plan:	Title: <i>Introduction: Infinity Mirror</i>	Scale: 1:24	EX 500 Drawing NO.
							Drawn by: <i>Eve Frudakis</i> Date: 11.03.2021	

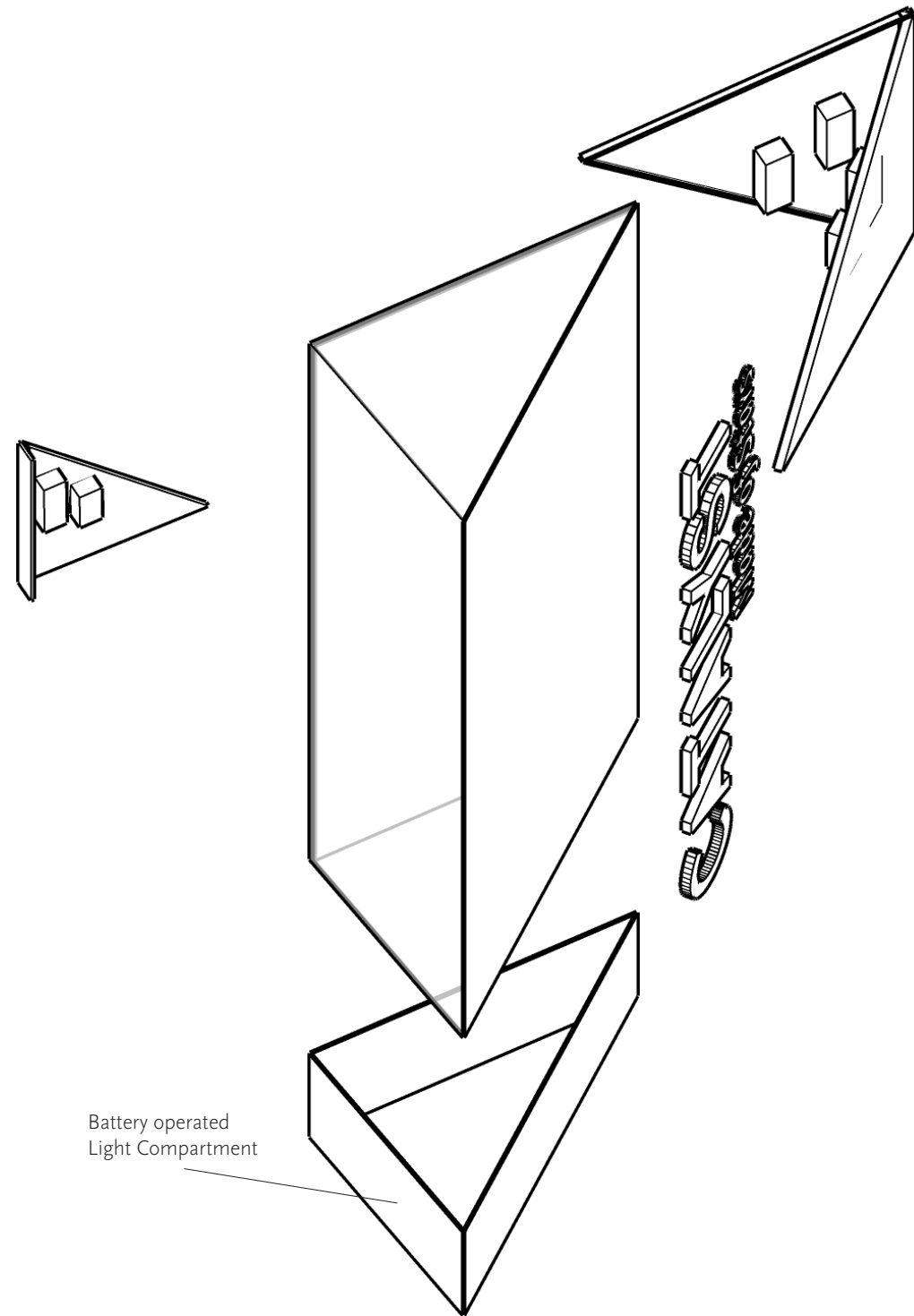

Battery operated
Light Compartment

1 :: 00A.01.GR01 Exploded
Scale: N/A

Sign Type A
00A.01.GR02

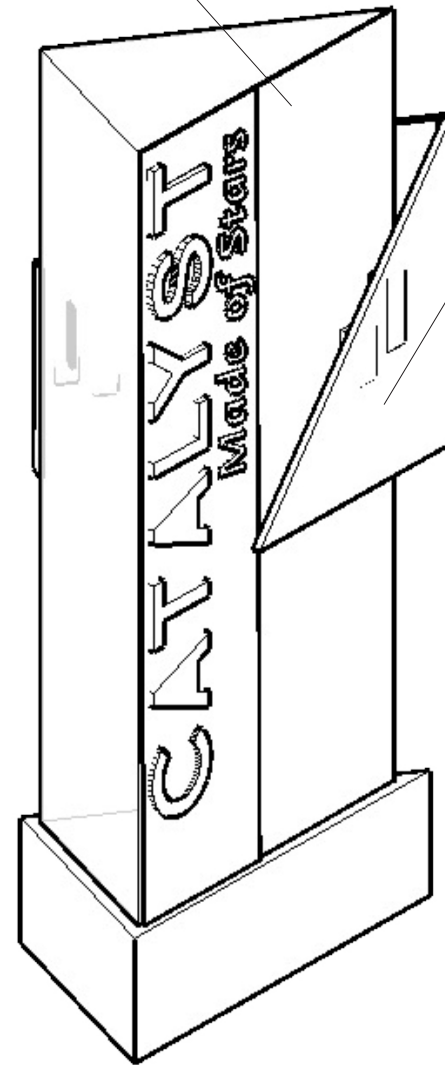

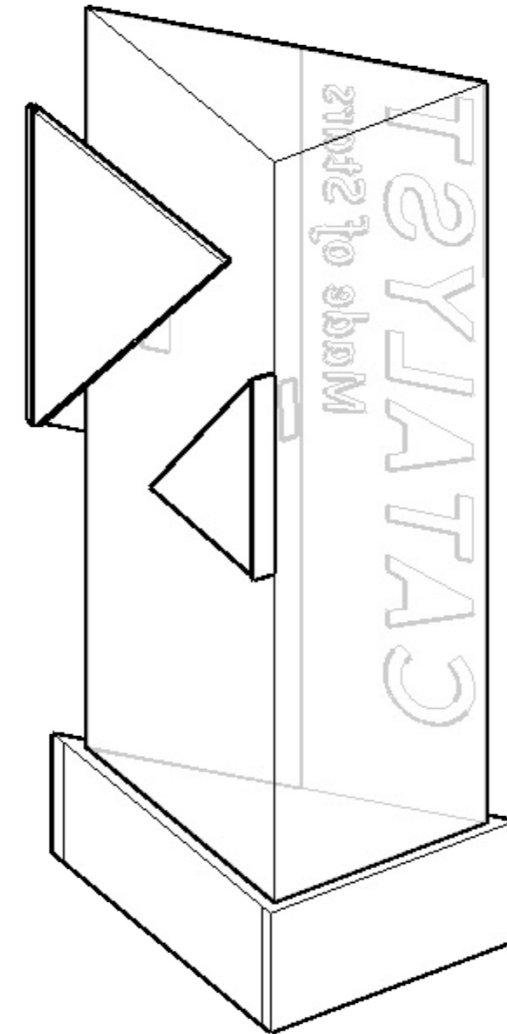

Sign Type B
a



1 :: 00A.01.GR01 Perspective View
Scale: 1/2" = 1'

2 :: 00A.01.GR02 Perspective View
Scale: 1/2" = 1'

Eve Frudakis <i>Exhibition and Experience Design</i>	Fashion Institute of Technology <i>School of Graduate Studies</i> 272 West 27th St. New York, NY 10011	Project: 	Client: 	DISCLAIMER This is an unpublished and proprietary work simultaneously protected under copyright, trade secret, and like laws of the United States and other countries. All rights reserved. These materials may not be reproduced, displayed, distributed, nor may be the information therein be used or disclosed in whole or in part, without the express written permission of Eve Frudakis.	Key Plan:	Title: <i>Area Introduction</i>	Scale: 1:24	EX 501 Drawing NO.
							Drawn by: <i>Eve Frudakis</i>	
EXHIBITION DOCUMENTATION								

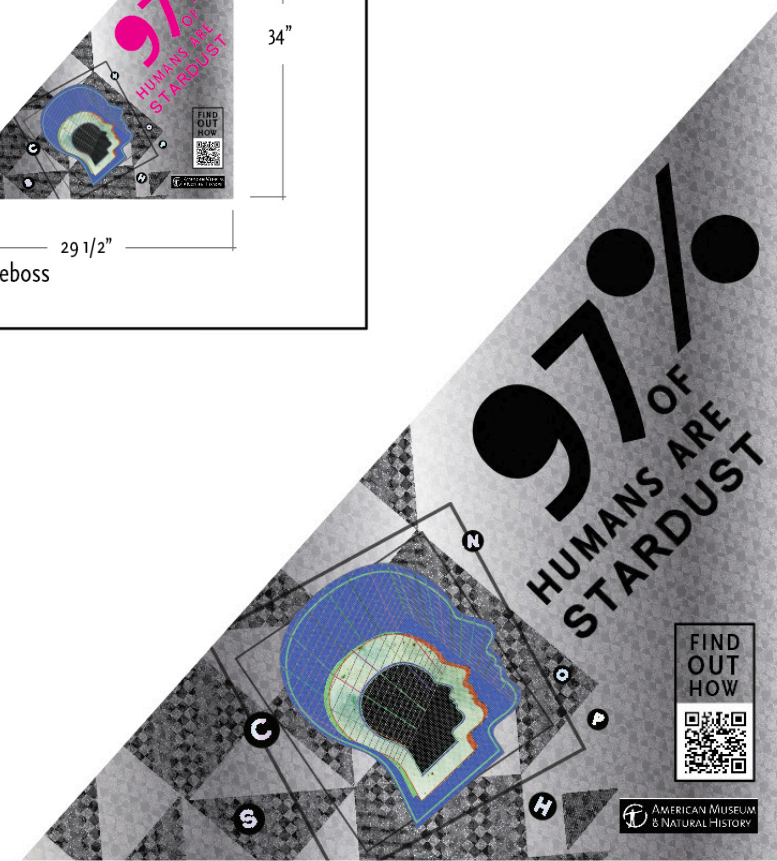
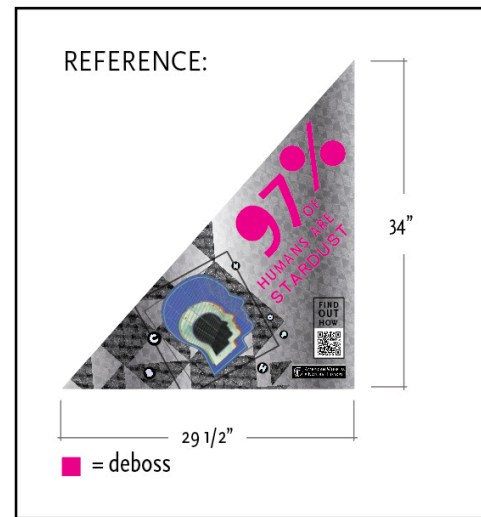

1 :: ooA.01.GRo2 Side "A"
Scale: N/A

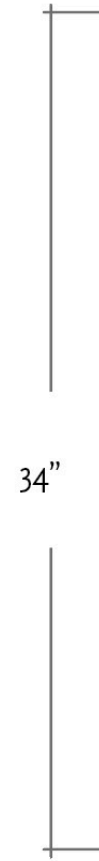
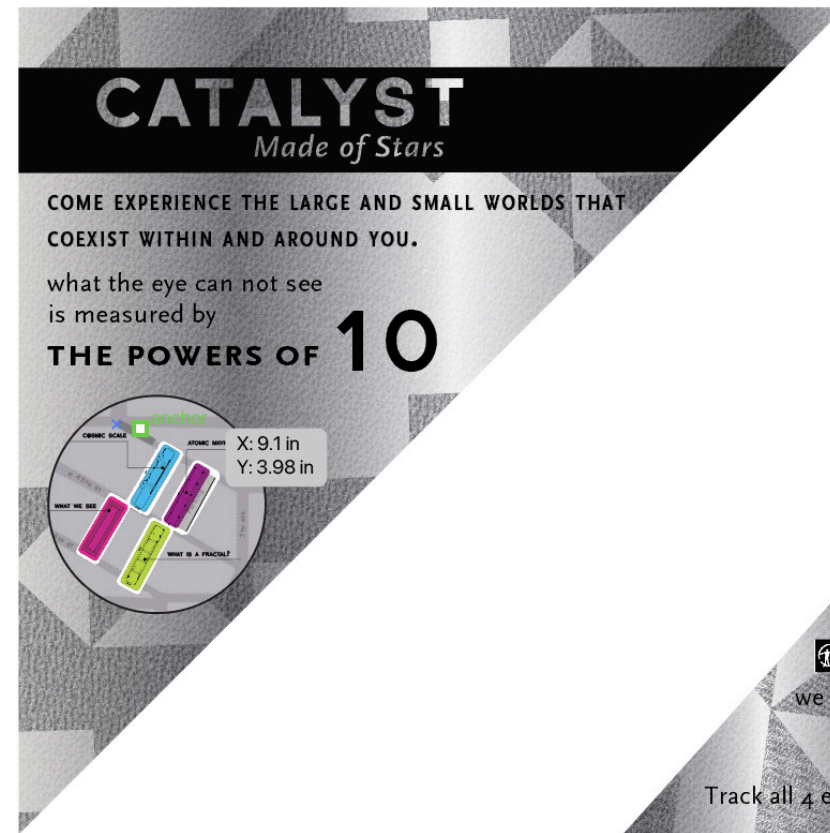

2 :: ooA.01.GRo2 Side "B"
Scale: N/A

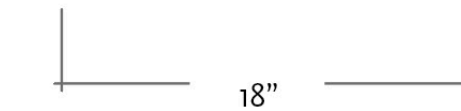

3 :: ooA.01.GRo2 Side "B-2"
Scale: N/A

Eve Frudakis <i>Exhibition and Experience Design</i> EXHIBITION DOCUMENTATION	Fashion Institute of Technology <i>School of Graduate Studies</i> 272 West 27th St. New York, NY 10011	Project: 	Client: 	DISCLAIMER This is an unpublished and proprietary work simultaneously protected under copyright, trade secret, and like laws of the United States and other countries. All rights reserved. These materials may not be reproduced, displayed, distributed, nor may be the information therein be used or disclosed in whole or in part, without the express written permission of Eve Frudakis.	Key Plan:	Title: <i>Area Introduction</i>	Scale: N/A	EX 502 Drawing NO.
							Drawn by: <i>Eve Frudakis</i> Date: 11.03.2021	

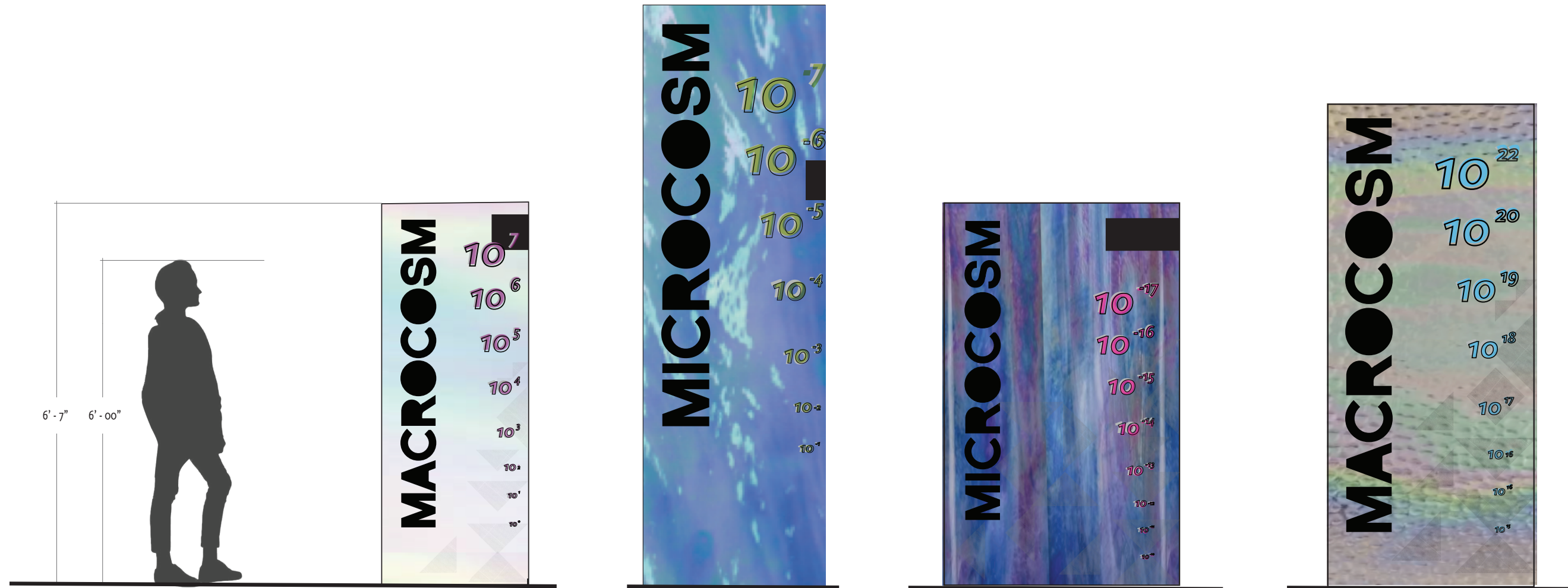

1 :: 01A.03.GR01 Elevation Front View "A"
Scale 1/2" = 1'

2 :: 02A.03.GR01 Elevation Front View "A"
Scale 1/2" = 1'

2 :: 03A.03.GR01 Elevation Front View "A"
Scale 1/2" = 1'

2 :: 04A.03.GR01 Elevation Front View "A"
Scale 1/2" = 1'

Eve Frudakis
Exhibition and Experience Design

Fashion Institute of Technology
School of Graduate Studies
272 West 27th St.
New York, NY 10011

Project:



Client:



DISCLAIMER

This is an unpublished and proprietary work simultaneously protected under copyright, trade secret, and like laws of the United States and other countries. All rights reserved. These materials may not be reproduced, displayed, distributed, nor may be the information therein be used or disclosed in whole or in part, without the express written permission of Eve Frudakis.

Key Plan:

Title:
Area Introduction

Scale:
1/2"=1'

Drawn by: Eve Frudakis

Date: 11.03.2021

EX 503

Drawing NO.

EXHIBITION DOCUMENTATION



1 :: 01A.03.GR01 Elevation Front View "A"
Scale 1/2 = 1'

2 :: 01A.03.GR01 Side View "B"
Scale 1/2 = 1'

3 :: 01A.03.GR01 Side View "C"
Scale 1/2 = 1'

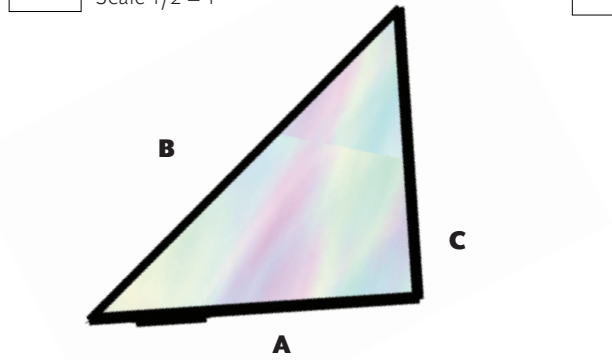

4 :: 01A.03.GR01 Elevation Top View
Scale 1/2 = 1'

Eve Frudakis <i>Exhibition and Experience Design</i> EXHIBITION DOCUMENTATION	Fashion Institute of Technology <i>School of Graduate Studies</i> 272 West 27th St. New York, NY 10011	Project: CATALYST <i>Made of Stars</i>	Client: AMERICAN MUSEUM OF NATURAL HISTORY	DISCLAIMER This is an unpublished and proprietary work simultaneously protected under copyright, trade secret, and like laws of the United States and other countries. All rights reserved. These materials may not be reproduced, displayed, distributed, nor may be the information therein be used or disclosed in whole or in part, without the express written permission of Eve Frudakis.	Key Plan: 	Title: Area Introduction	Scale: 1:24	EX 504
							Drawn by: <i>Eve Frudakis</i> Date: 11.03.2021	Drawing NO.

:: 01A.03.GR01 | Area Introduction | Sign Type C

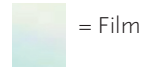

Eve Frudakis <i>Exhibition and Experience Design</i>	Fashion Institute of Technology <i>School of Graduate Studies</i> 272 West 27th St. New York, NY 10011	Project: 	Client: 	DISCLAIMER This is an unpublished and proprietary work simultaneously protected under copyright, trade secret, and like laws of the United States and other countries. All rights reserved. These materials may not be reproduced, displayed, distributed, nor may be the information therein be used or disclosed in whole or in part, without the express written permission of Eve Frudakis.	Key Plan: 	Title: Area Introduction	Scale: 1:24	EX 505 Drawing NO.
							Drawn by: <i>Eve Frudakis</i> Date: 11.03.2021	
EXHIBITION DOCUMENTATION								

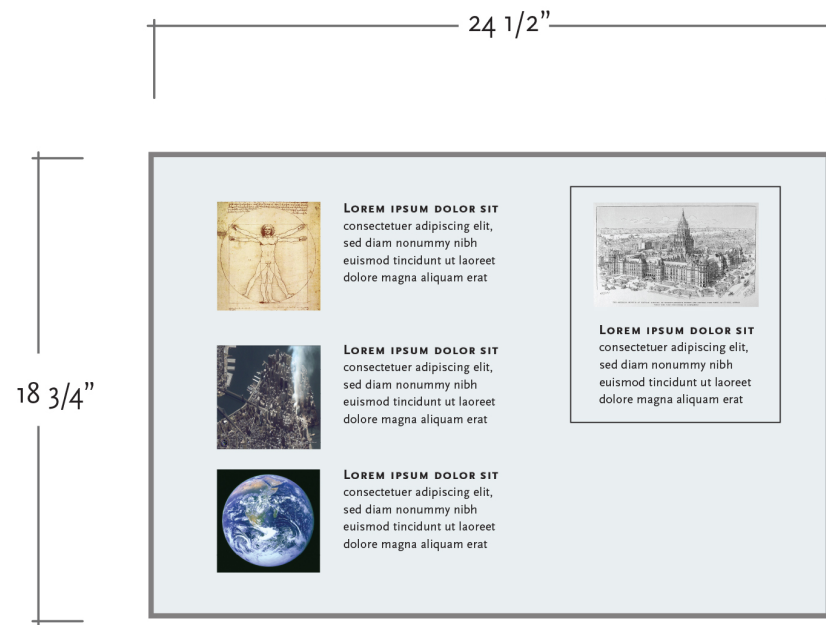

1 :: 01A.03.GRo2 Side "B"
Scale N/A

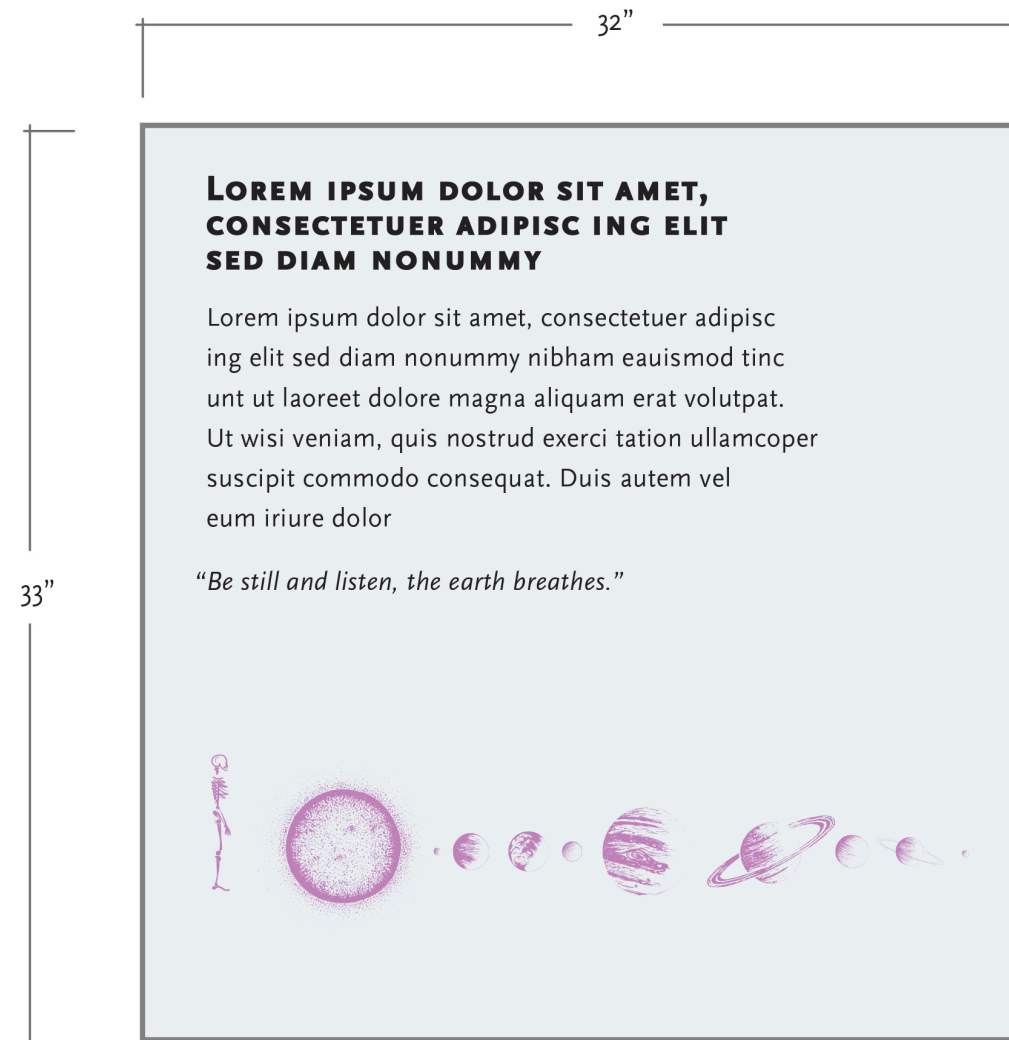

2 :: 01A.03.GRo2 Side "C"
Scale N/A

:: 02A.03.GR01 | Area Introduction | Sign Type C

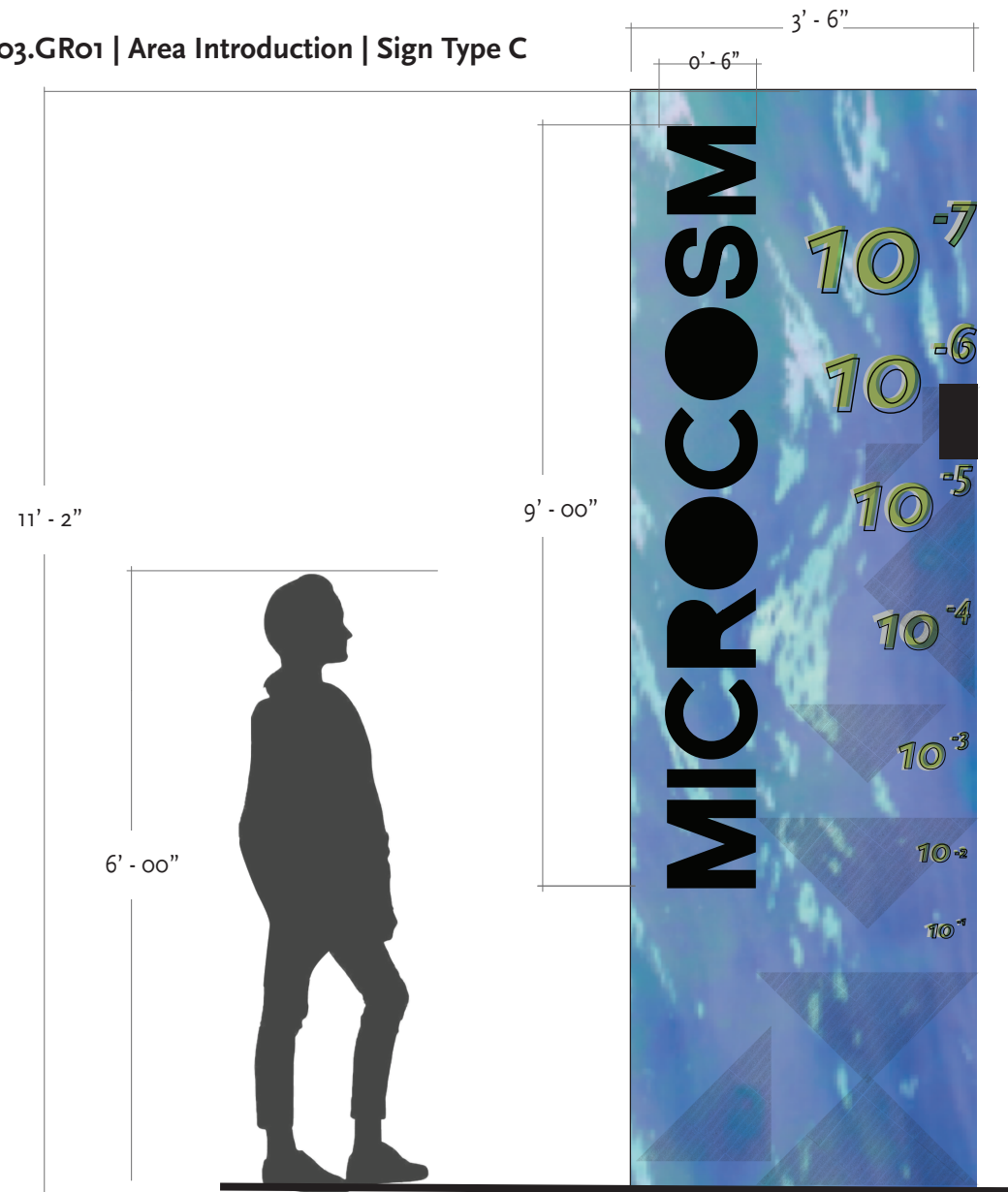

1 :: 02A.03.GR01 Elevation Side View "A"
Scale 1/2 = 1'

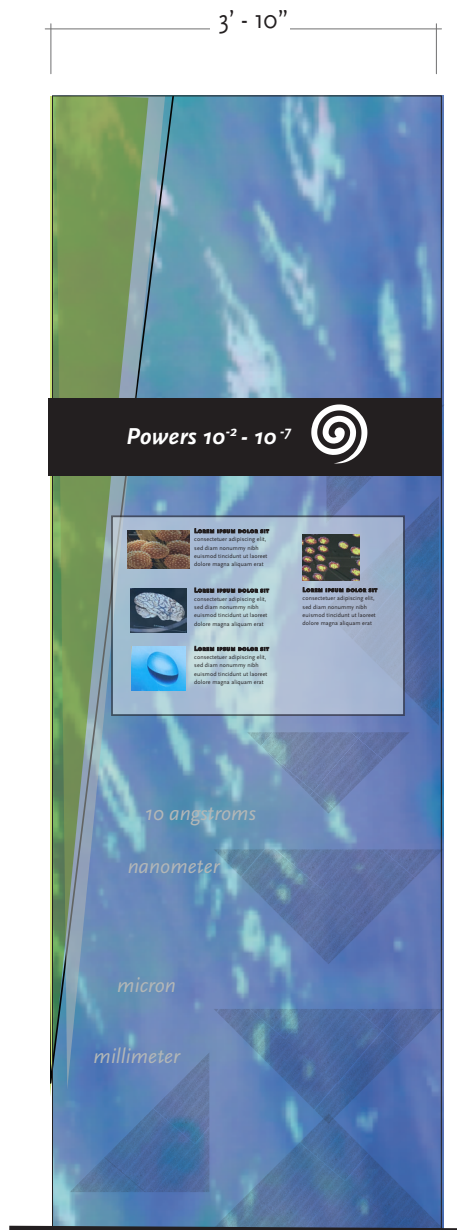

2 :: 02A.03.GR01 Side View "B"
Scale 1/2 = 1'

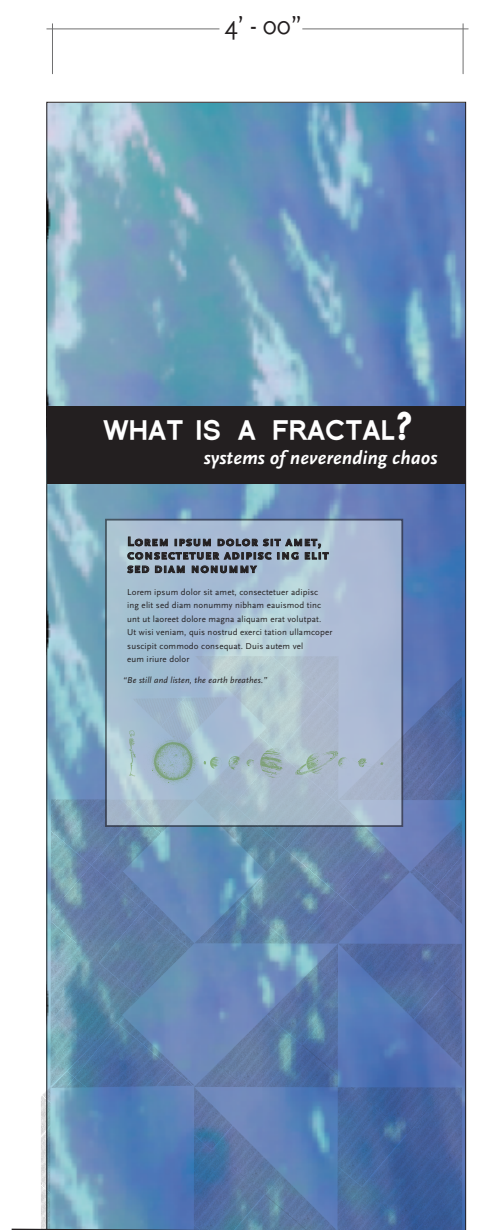

3 :: 02 A.03.GR01 Side View "C"
Scale 1/2 = 1'

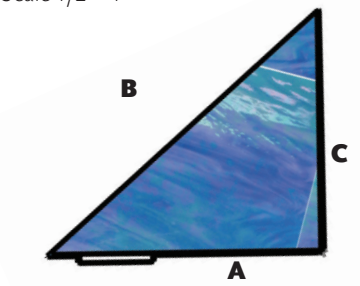
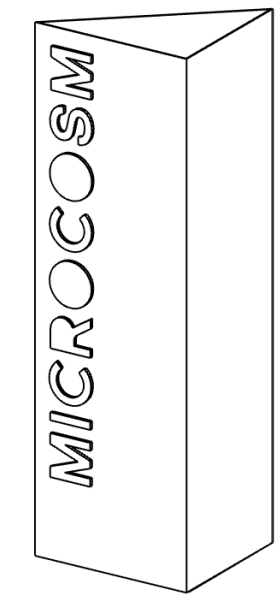

2 :: 02A.03.GR01 Side View "B"
Scale 1/2 = 1'

Eve Frudakis <i>Exhibition and Experience Design</i> EXHIBITION DOCUMENTATION	Fashion Institute of Technology <i>School of Graduate Studies</i> 272 West 27th St. New York, NY 10011	Project: CATALYST <i>Made of Stars</i>	Client: AMERICAN MUSEUM OF NATURAL HISTORY	DISCLAIMER This is an unpublished and proprietary work simultaneously protected under copyright, trade secret, and like laws of the United States and other countries. All rights reserved. These materials may not be reproduced, displayed, distributed, nor may be the information therein be used or disclosed in whole or in part, without the express written permission of Eve Frudakis.	Key Plan: 	Title: Area Introduction	Scale: 1/2"=1'	EX 507 Drawing NO.
					Drawn by: <i>Eve Frudakis</i> Date: 11.03.2021			

:: 02A.03.GR01 | Area Introduction | Sign Type C

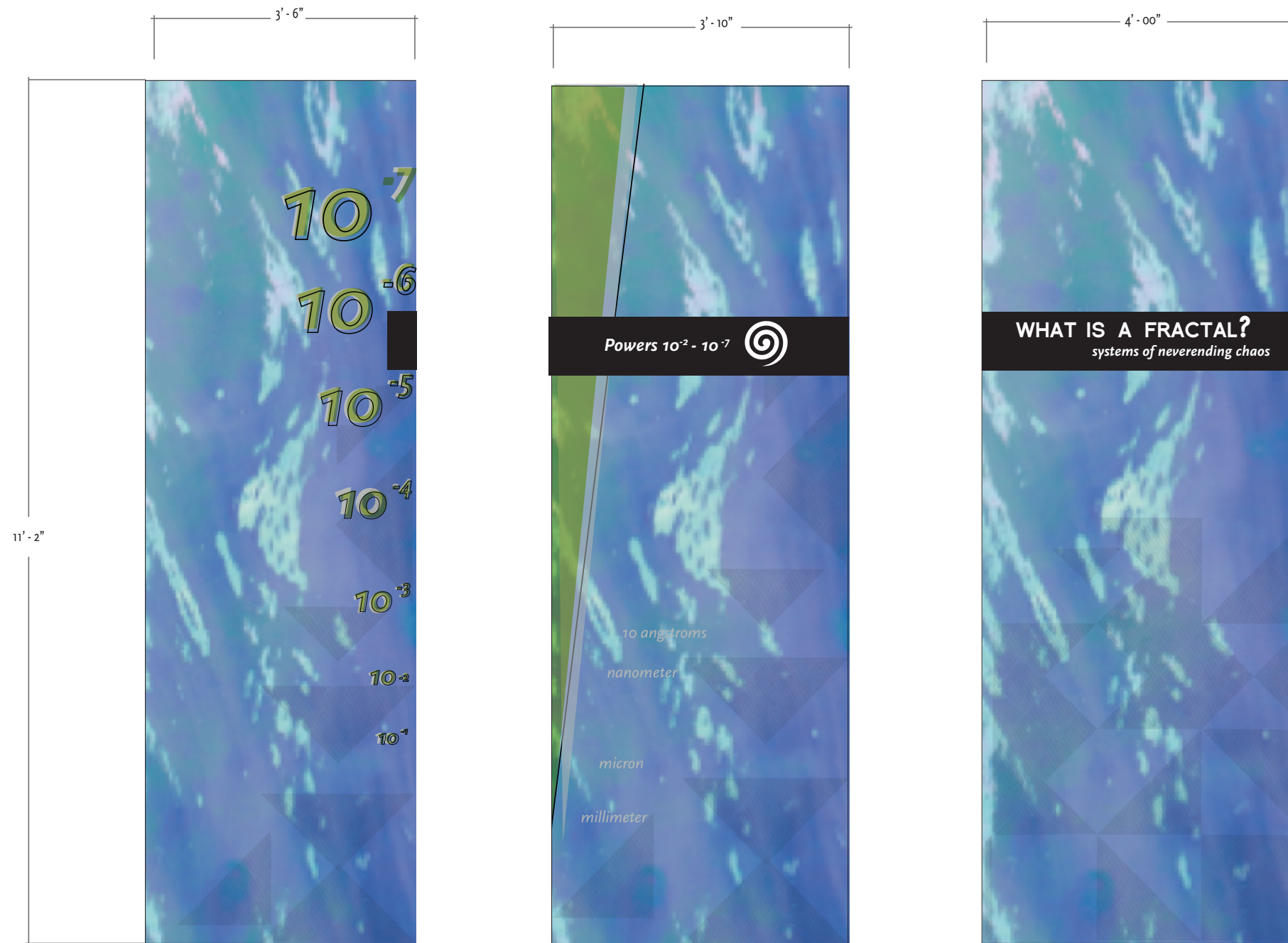
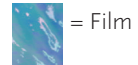

1 :: 02A.03.GR01 Elevation Side View "A"
Scale: N/A

2 :: 02A.03.GR01 Side View "B"
Scale: N/A

3 :: 02 A.03.GR01 Side View "C"
Scale: N/A

Eve Frudakis <i>Exhibition and Experience Design</i>	Fashion Institute of Technology <i>School of Graduate Studies</i> 272 West 27th St. New York, NY 10011	Project: 	Client: 	DISCLAIMER This is an unpublished and proprietary work simultaneously protected under copyright, trade secret, and like laws of the United States and other countries. All rights reserved. These materials may not be reproduced, displayed, distributed, nor may be the information therein be used or disclosed in whole or in part, without the express written permission of Eve Frudakis.	Key Plan: 	Title: Area Introduction	Scale: N/A	EX 508 Drawing NO.
	EXHIBITION DOCUMENTATION					Drawn by: <i>Eve Frudakis</i> Date: 11.03.2021		

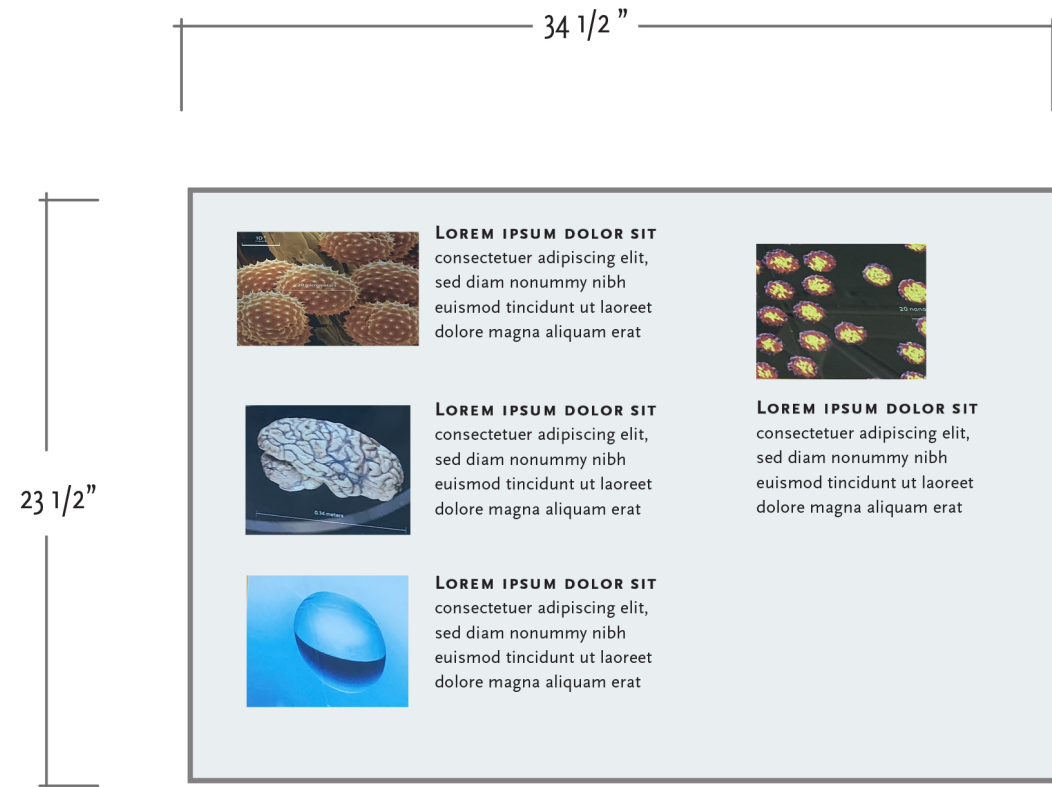

1 :: 02A.03.GRo2 Side "B"
Scale N/A

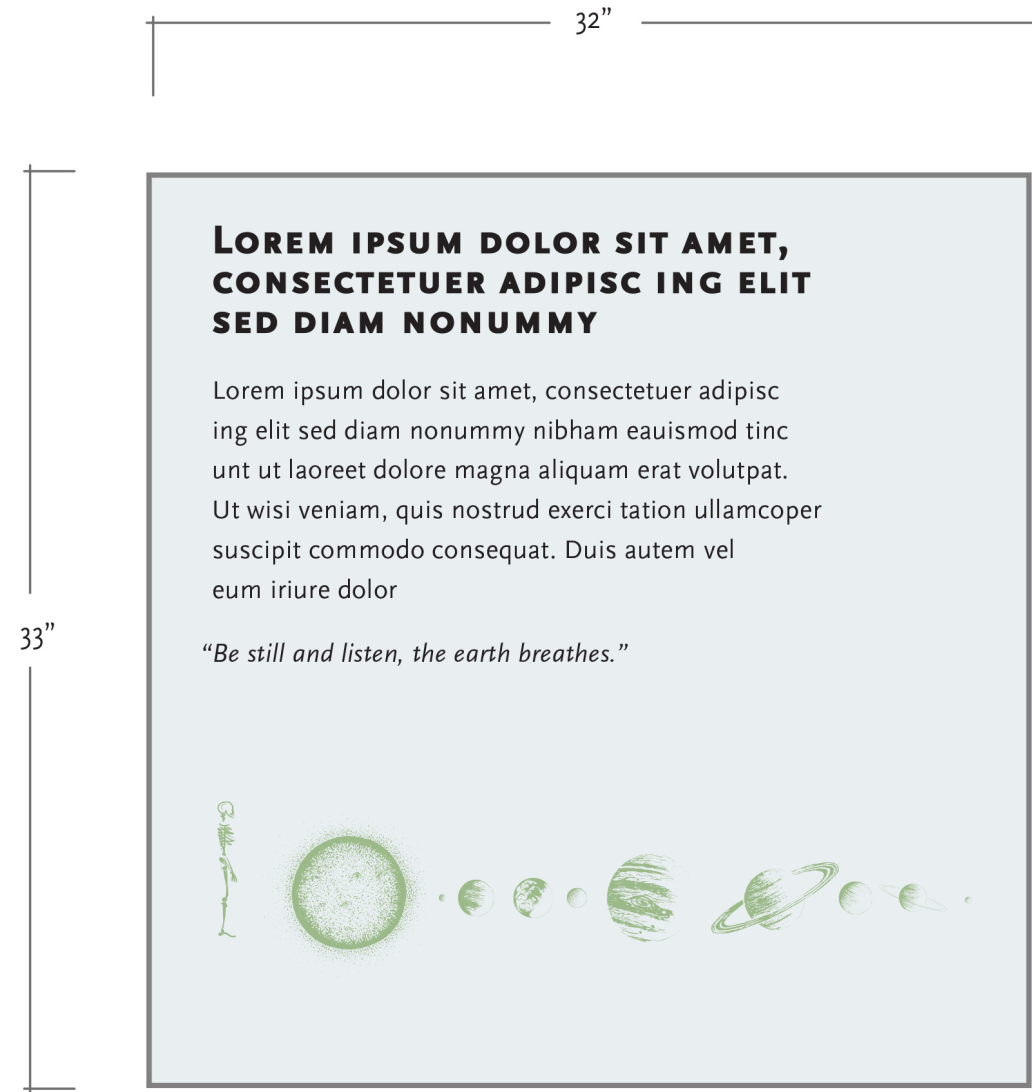

2 :: 02A.03.GRo2 Side "C"
Scale N/A

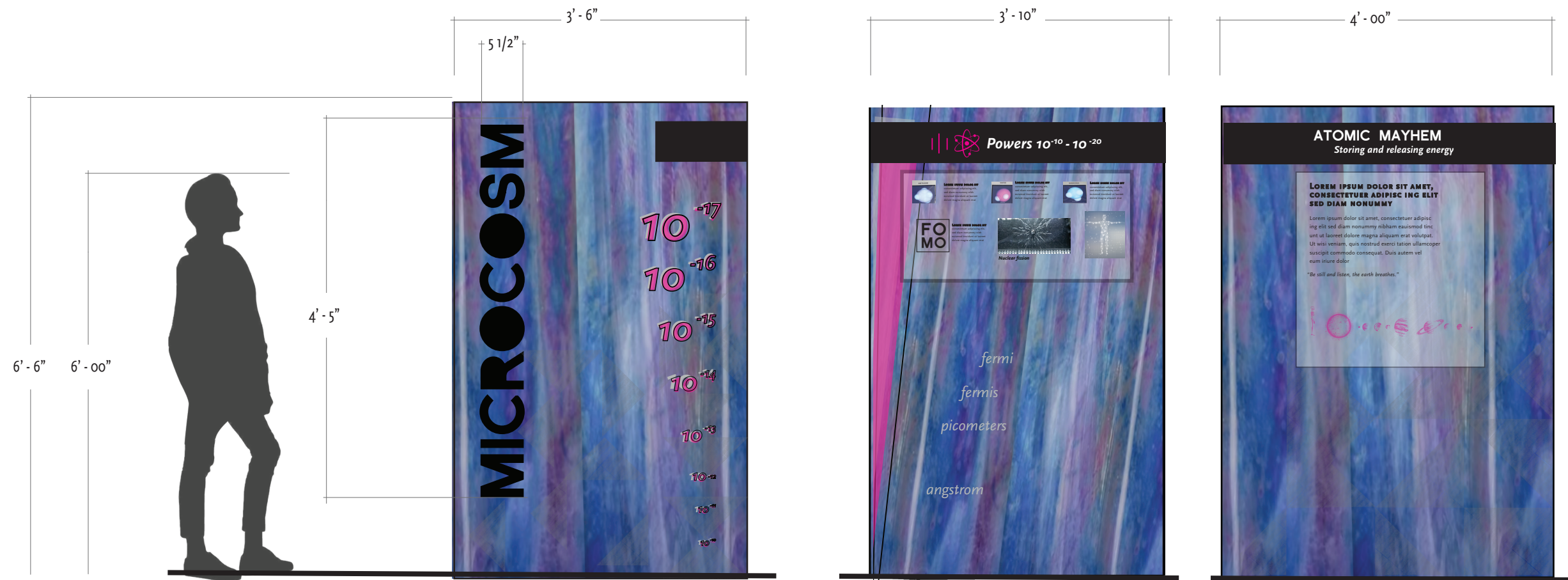

1 :: 03A.03.GR01 Elevation Side View "A"
Scale 1/2" = 1'

2 :: 03A.03.GR01 Side View "B"
Scale 1/2" = 1'

3 :: 03A.03.GR01 Side View "C"
Scale 1/2" = 1'

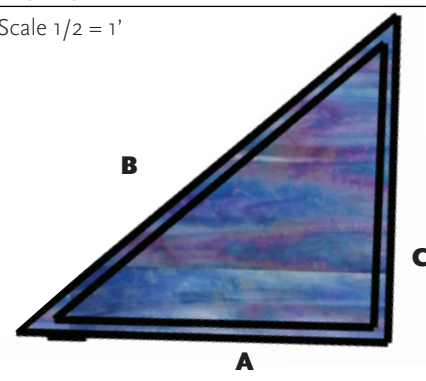

4 :: 03A.03.GR01 Side Top "C"
Scale 1/2" = 1'

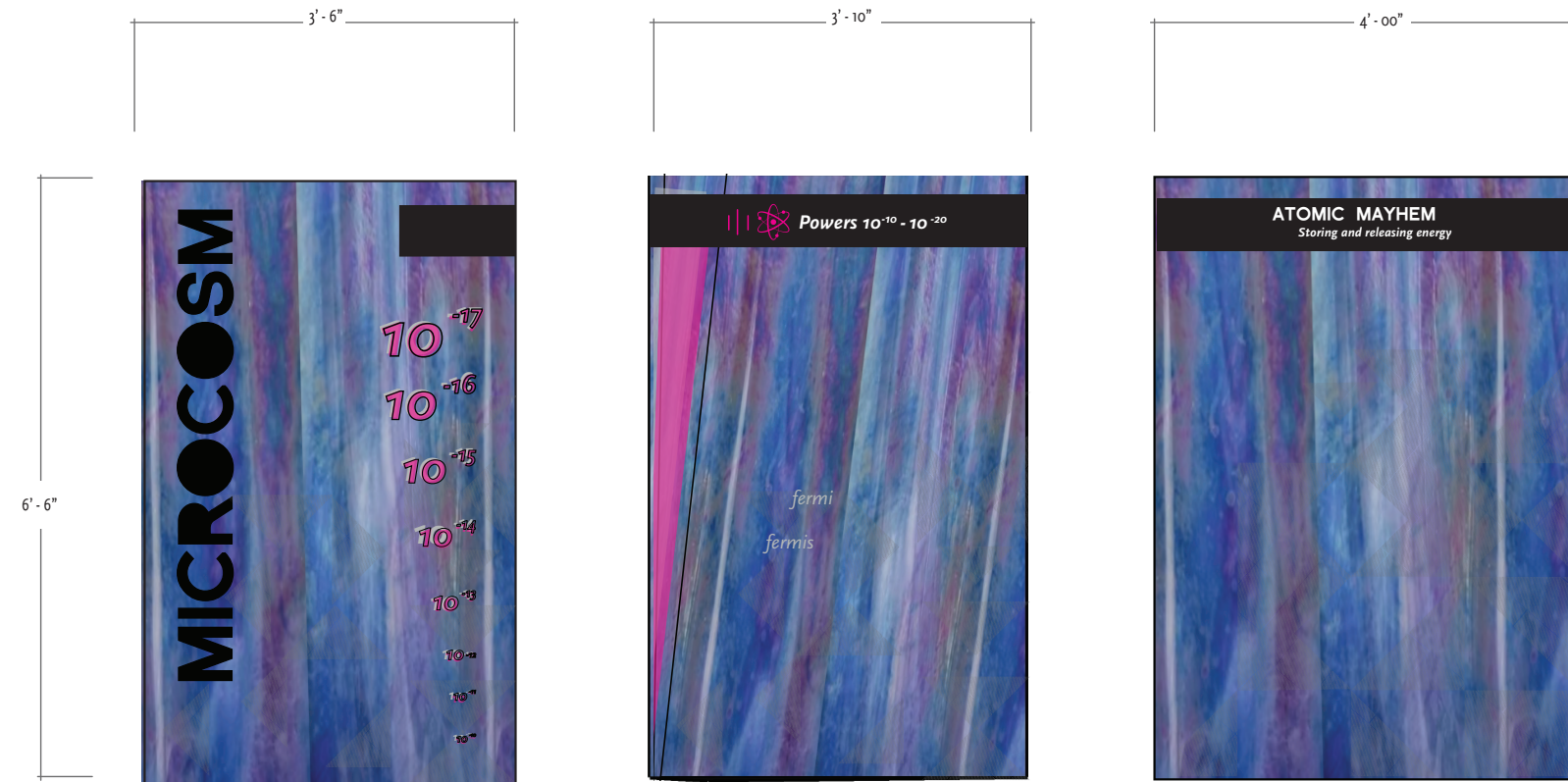

Eve Frudakis Exhibition and Experience Design EXHIBITION DOCUMENTATION	Fashion Institute of Technology School of Graduate Studies 272 West 27th St. New York, NY 10011	Project: 	Client: 	DISCLAIMER This is an unpublished and proprietary work simultaneously protected under copyright, trade secret, and like laws of the United States and other countries. All rights reserved. These materials may not be reproduced, displayed, distributed, nor may be the information therein be used or disclosed in whole or in part, without the express written permission of Eve Frudakis.	Key Plan: 	Title: Area Introduction	Scale: 1/2" = 1'	EX 510 Drawing NO.
							Drawn by: Eve Frudakis Date: 11.03.2021	



1 :: 01A.03.GR01 Side "A"
Scale: N/A

2 :: 01A.03.GR01 Side "B"
Scale: N/A

3 :: 01A.03.GR01 Side "C"
Scale: N/A

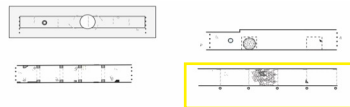
Eve Frudakis <i>Exhibition and Experience Design</i>	Fashion Institute of Technology <i>School of Graduate Studies</i> 272 West 27th St. New York, NY 10011	Project: 	Client: 	DISCLAIMER This is an unpublished and proprietary work simultaneously protected under copyright, trade secret, and like laws of the United States and other countries. All rights reserved. These materials may not be reproduced, displayed, distributed, nor may be the information therein be used or disclosed in whole or in part, without the express written permission of Eve Frudakis.	Key Plan: 	Title: <i>Area Introduction</i>	Scale: N/A	EX 511 Drawing NO.
							Drawn by: <i>Eve Frudakis</i> Date: 11.03.2021	

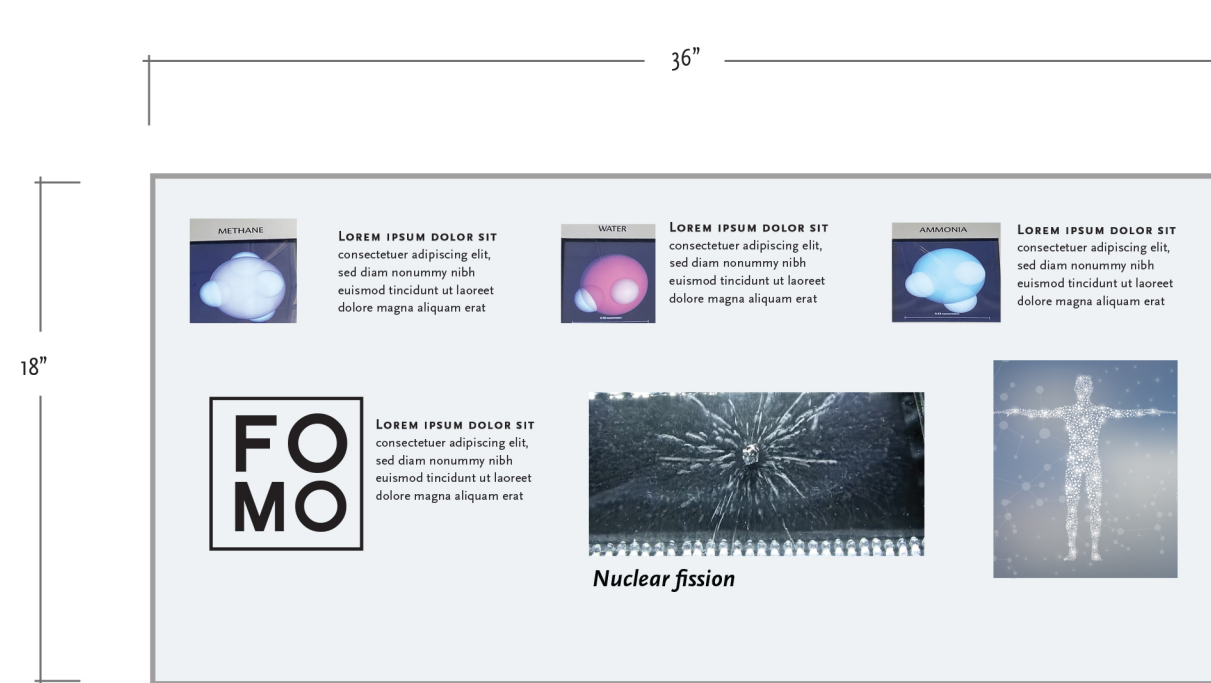

1 :: 03A.03.GRo2 Side "B"
Scale N/A

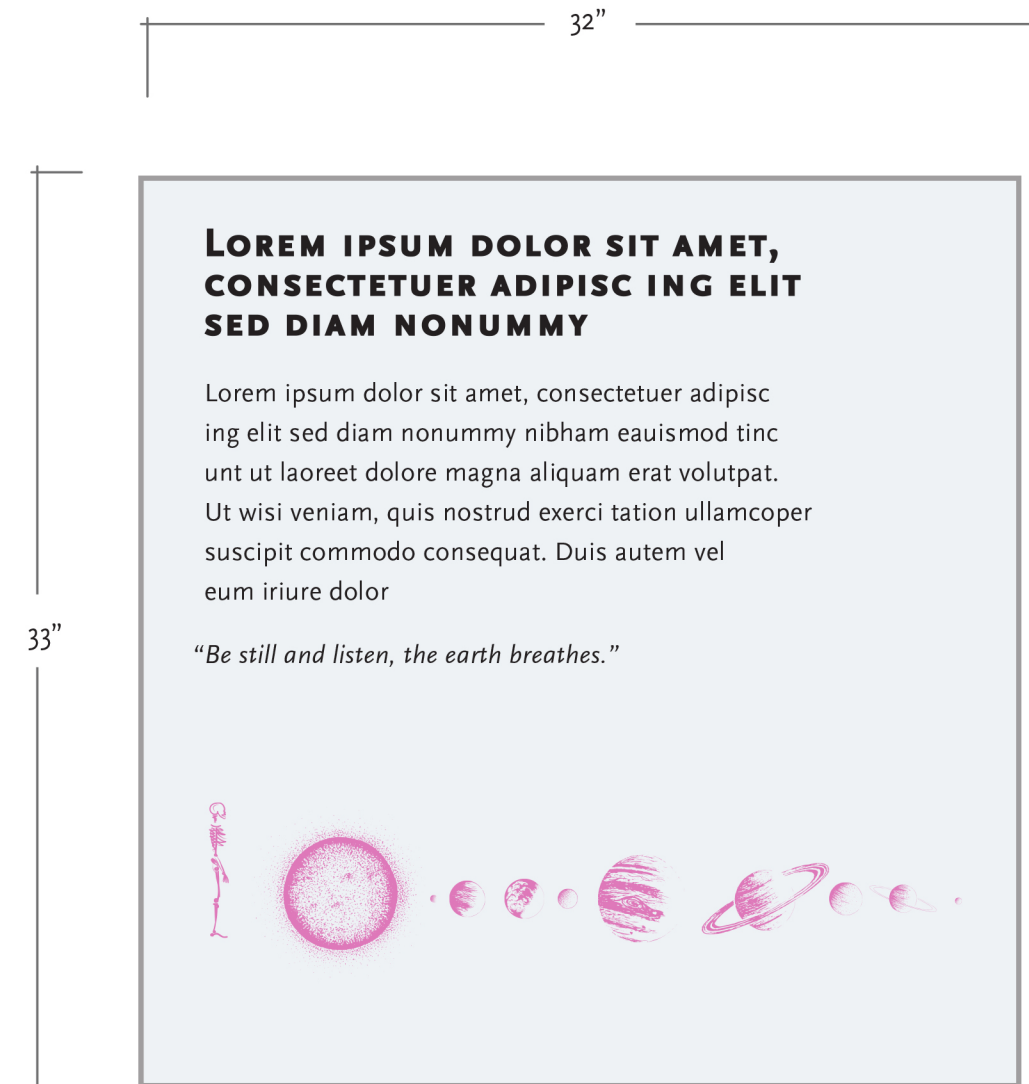

2 :: 03A.03.GRo2 Side "C"
Scale N/A

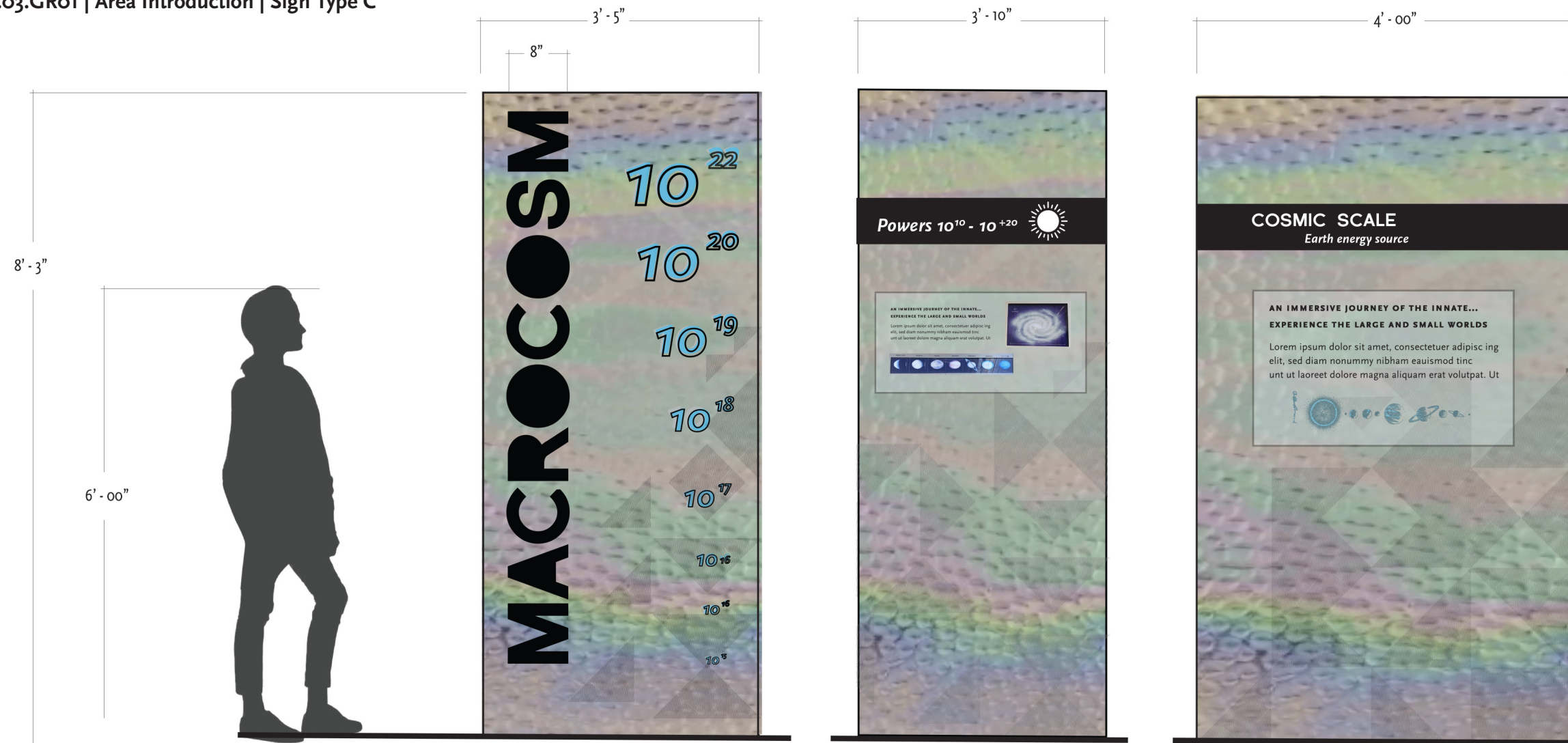

1 :: 04A.03.GR01 Elevation Side View "A"
Scale 1/2" = 1'

2 :: 04A.03.GR01 Side View "B"
Scale 1/2" = 1'

3 :: 04A.03.GR01 Side View "C"
Scale 1/2" = 1'

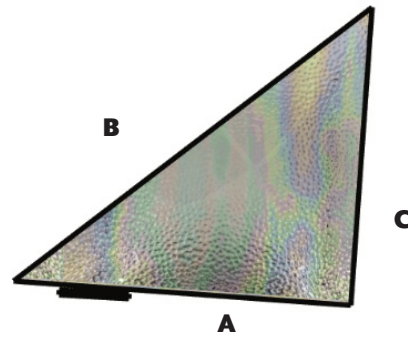

Eve Frudakis Exhibition and Experience Design EXHIBITION DOCUMENTATION	Fashion Institute of Technology School of Graduate Studies 272 West 27th St. New York, NY 10011	Project: CATALYST Made of Stars	Client: AMERICAN MUSEUM OF NATURAL HISTORY	DISCLAIMER This is an unpublished and proprietary work simultaneously protected under copyright, trade secret, and like laws of the United States and other countries. All rights reserved. These materials may not be reproduced, displayed, distributed, nor may be the information therein be used or disclosed in whole or in part, without the express written permission of Eve Frudakis.	Key Plan: 	Title: Area Introduction	Scale: 1/2" = 1'	EX 513 Drawing NO.
							Drawn by: Eve Frudakis Date: 11.03.2021	

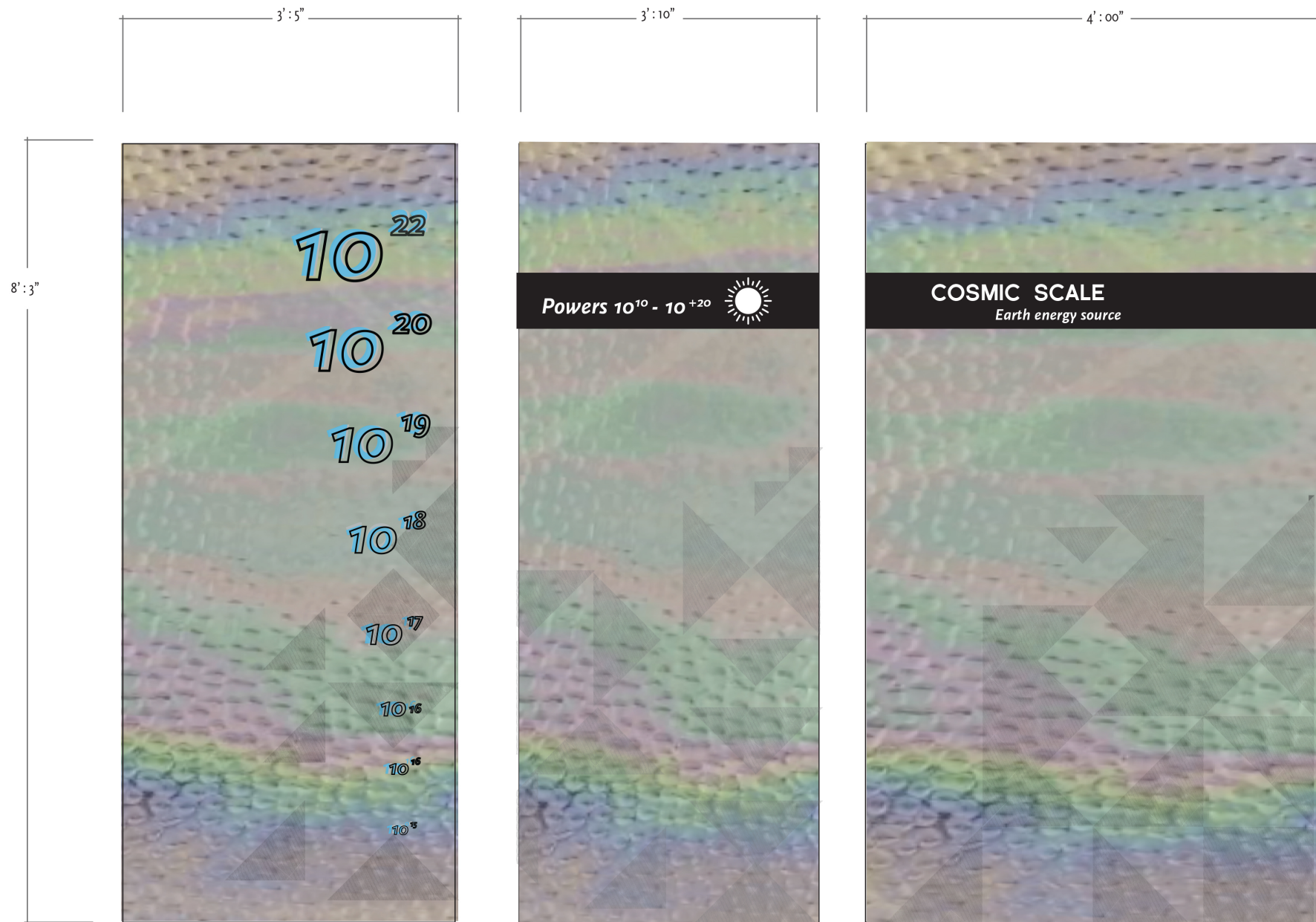

1 :: 04A.03.GRo1 Elevation Side View "A"
Scale 1/2 = 1'

2 :: 04A.03.GRo1 Side View "B"
Scale 1/2 = 1'

3 :: 04A.03.GRo1 Side View "C"
Scale 1/2 = 1'

Eve Frudakis <i>Exhibition and Experience Design</i>	Fashion Institute of Technology <i>School of Graduate Studies</i> 272 West 27th St. New York, NY 10011	Project:	Client:	DISCLAIMER <small>This is an unpublished and proprietary work simultaneously protected under copyright, trade secret, and like laws of the United States and other countries. All rights reserved. These materials may not be reproduced, displayed, distributed, nor may be the information therein be used or disclosed in whole or in part, without the express written permission of Eve Frudakis.</small>	Key Plan:	Title: <i>Area Introduction</i>	Scale: N/A	EX 514 Drawing NO.
					Drawn by: <i>Eve Frudakis</i> Date: 11.03.2021			
EXHIBITION DOCUMENTATION								

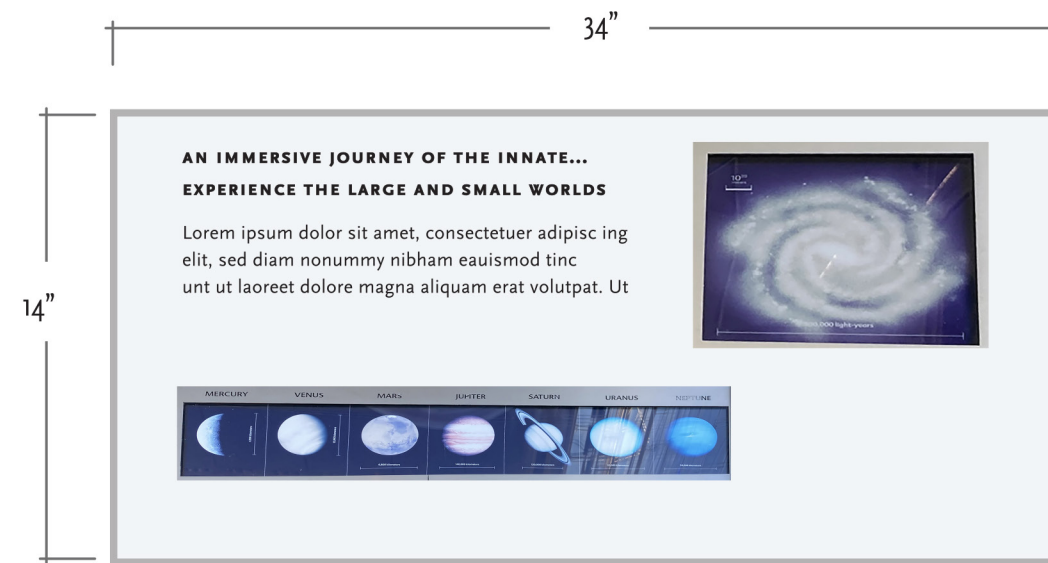

1 :: 04A.03.GRo2 Side "B"
Scale N/A

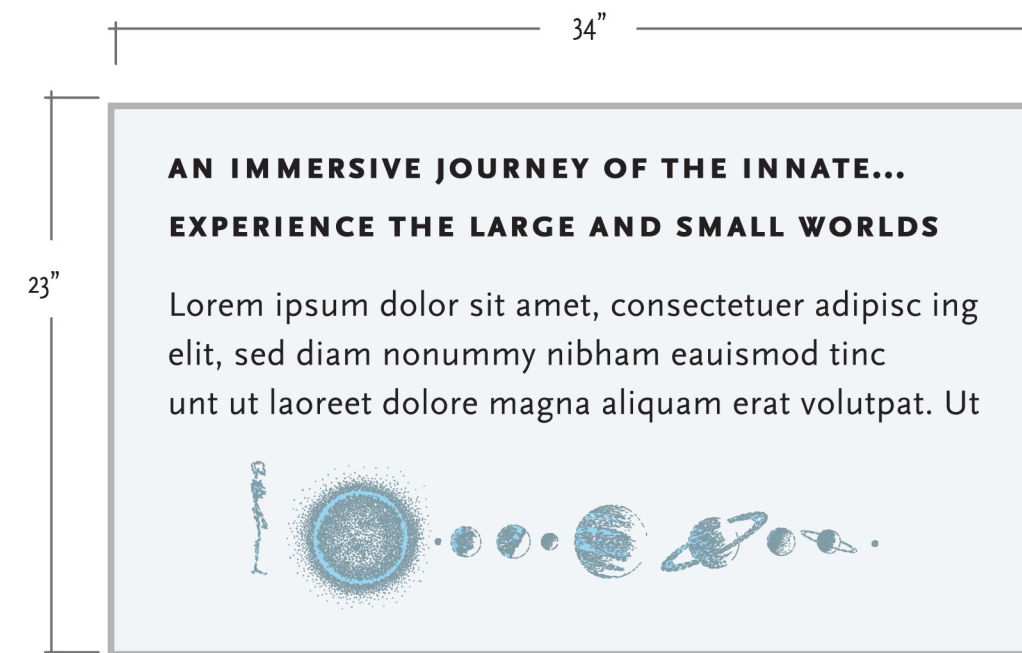

2 :: 04A.03.GRo2 Side "C"
Scale N/A

Eve Frudakis <i>Exhibition and Experience Design</i>	Fashion Institute of Technology <i>School of Graduate Studies</i> 272 West 27th St. New York, NY 10011	Project:	Client:	DISCLAIMER This is an unpublished and proprietary work simultaneously protected under copyright, trade secret, and like laws of the United States and other countries. All rights reserved. These materials may not be reproduced, displayed, distributed, nor may be the information therein be used or disclosed in whole or in part, without the express written permission of Eve Frudakis.	Key Plan:	Title: <i>Area Introduction</i>	Scale: N/A	EX 515 Drawing NO.
					Drawn by: <i>Eve Frudakis</i> Date: 11.03.2021			
EXHIBITION DOCUMENTATION								

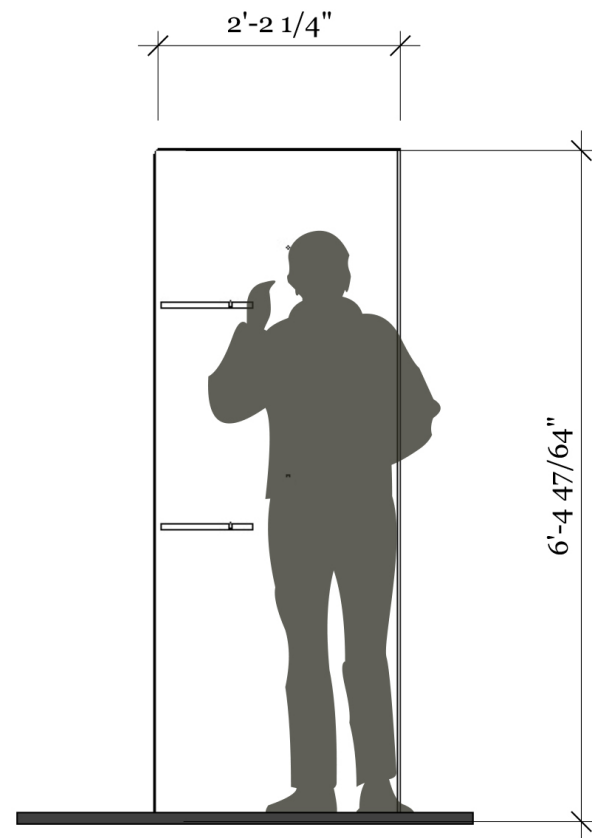

1 :: 01A.o8.GR01 Elevation Side View "A"
Scale 1/2 = 1'

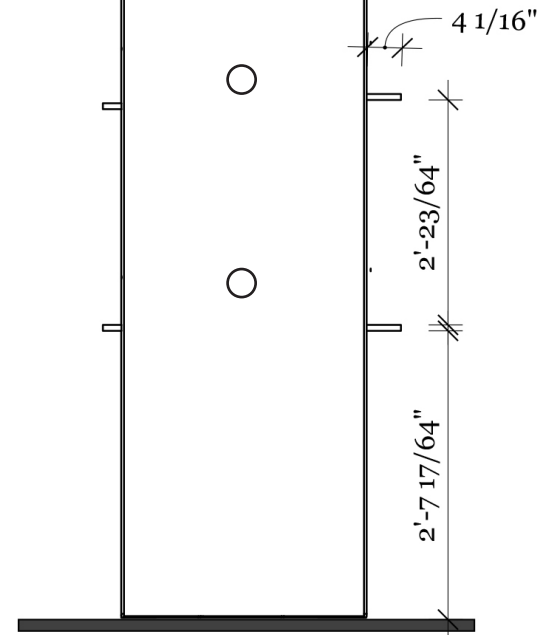



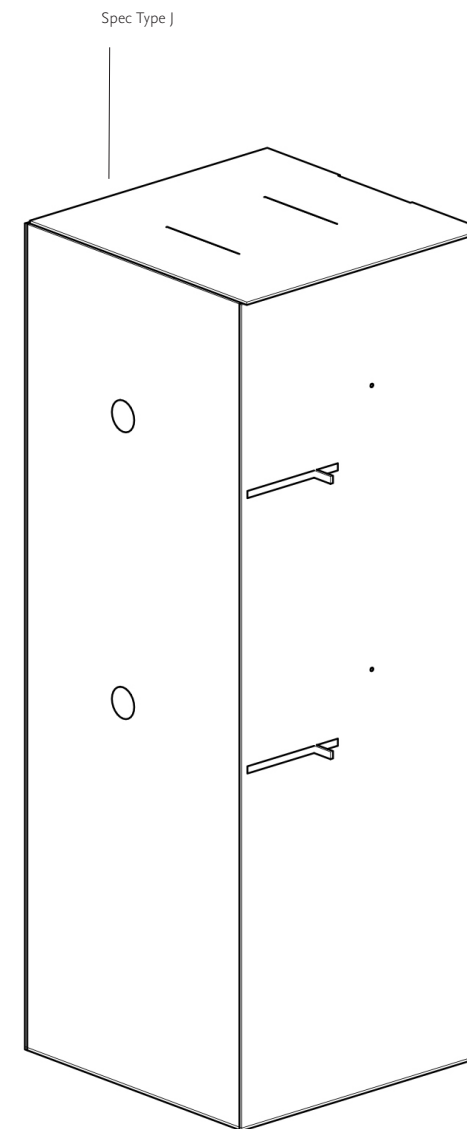

2 :: 01A.o8.GR01 Elevation Side View "B"
Scale 1/2 = 1'

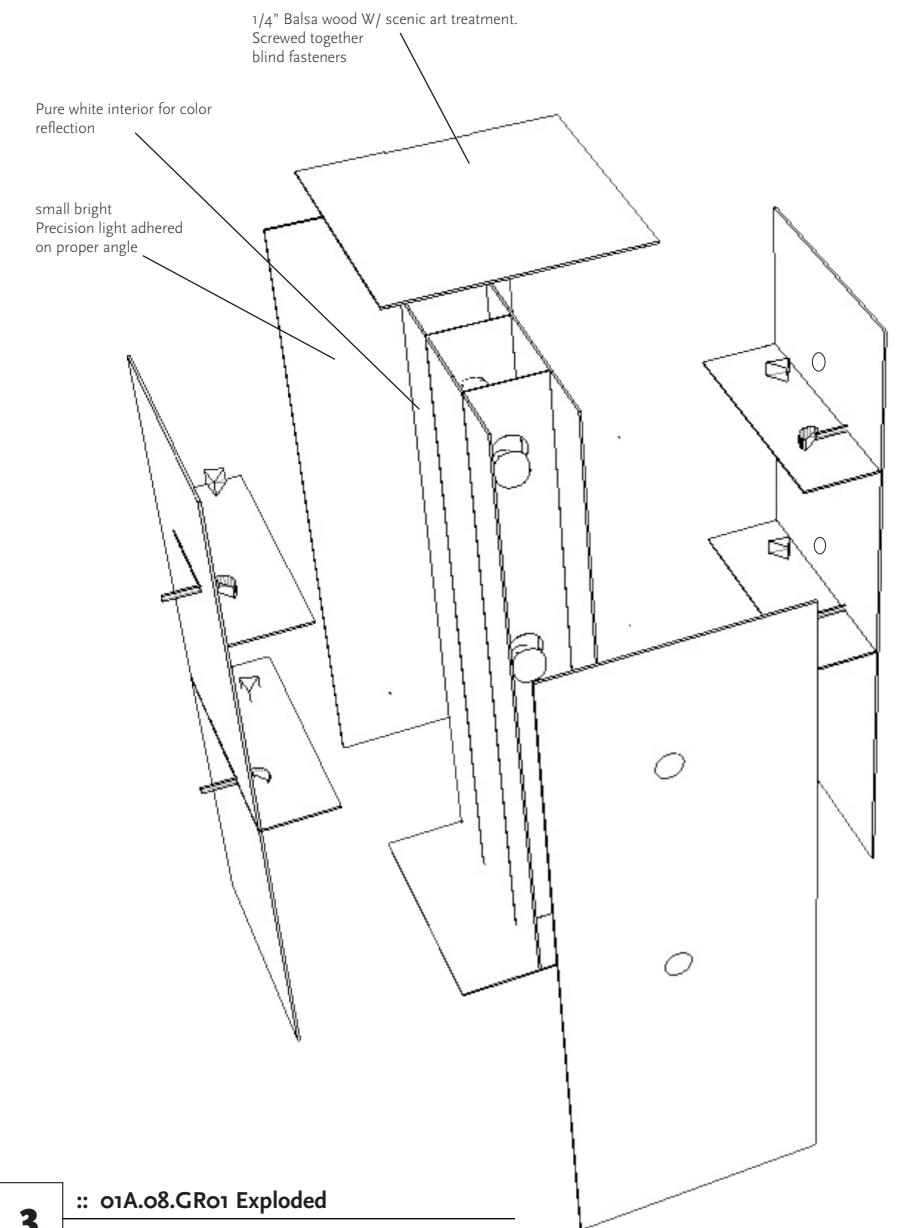

3 :: 01A.o8.GR01 Perspective Reference
Scale N/A



3 :: 01A.o8.GR01 Exploded
Scale N/A

<p>Eve Frudakis Exhibition and Experience Design</p> <hr/> <p>EXHIBITION DOCUMENTATION</p>	<p>Fashion Institute of Technology School of Graduate Studies 272 West 27th St. New York, NY 10011</p>	<p>Project:</p> 	<p>Client:</p> 	<p>DISCLAIMER This is an unpublished and proprietary work simultaneously protected under copyright, trade secret, and like laws of the United States and other countries. All rights reserved. These materials may not be reproduced, displayed, distributed, nor may be the information therein be used or disclosed in whole or in part, without the express written permission of Eve Frudakis.</p>	<p>Key Plan:</p> 	<p>Title: 01A Look, See, Hear</p>	<p>Scale: N/A</p> <p>Drawn by: Eve Frudakis</p> <p>Date: 11.03.2021</p>	 <p>EX 516</p> <p>Drawing NO.</p>
--	---	---	--	---	---	--	--	---



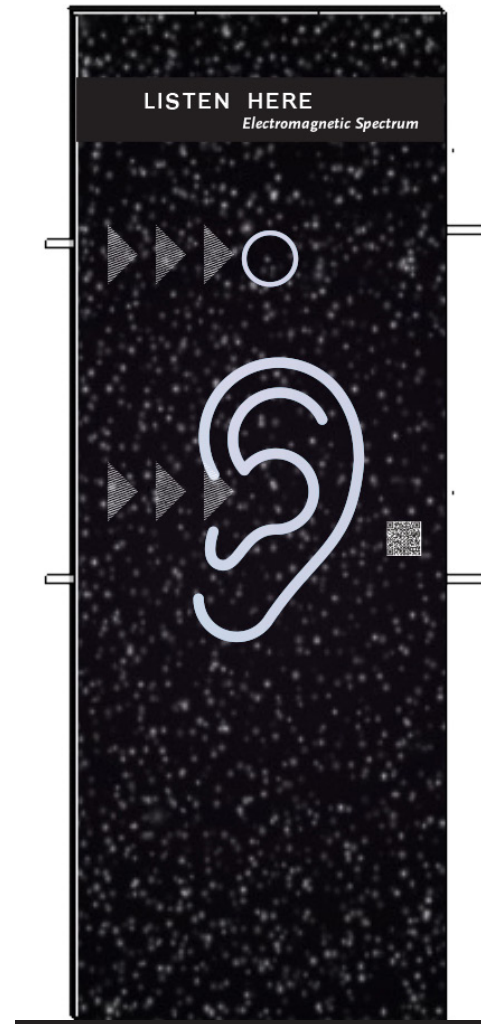

1 :: 01A.08.GR01 Elevation Side View "A"
Scale 1/2 = 1'



2 :: 01A.08.GR01 Elevation Side View "B"
Scale 1/2 = 1'

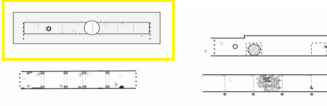

<p>Eve Frudakis Exhibition and Experience Design</p> <p>EXHIBITION DOCUMENTATION</p>	<p>Fashion Institute of Technology School of Graduate Studies 272 West 27th St. New York, NY 10011</p>	<p>Project:</p> <p>CATALYST Made of Stars</p>	<p>Client:</p> <p> AMERICAN MUSEUM OF NATURAL HISTORY</p>	<p>DISCLAIMER This is an unpublished and proprietary work simultaneously protected under copyright, trade secret, and like laws of the United States and other countries. All rights reserved. These materials may not be reproduced, displayed, distributed, nor may be the information therein be used or disclosed in whole or in part, without the express written permission of Eve Frudakis.</p>	<p>Key Plan:</p> 	<p>Title: 01A Look, See, Hear</p>	<p>Scale: N/A</p> <p>Drawn by: Eve Frudakis</p> <p>Date: 11.03.2021</p>	<p> EX 517</p> <p>Drawing NO.</p>
--	---	--	--	---	--	---------------------------------------	---	---

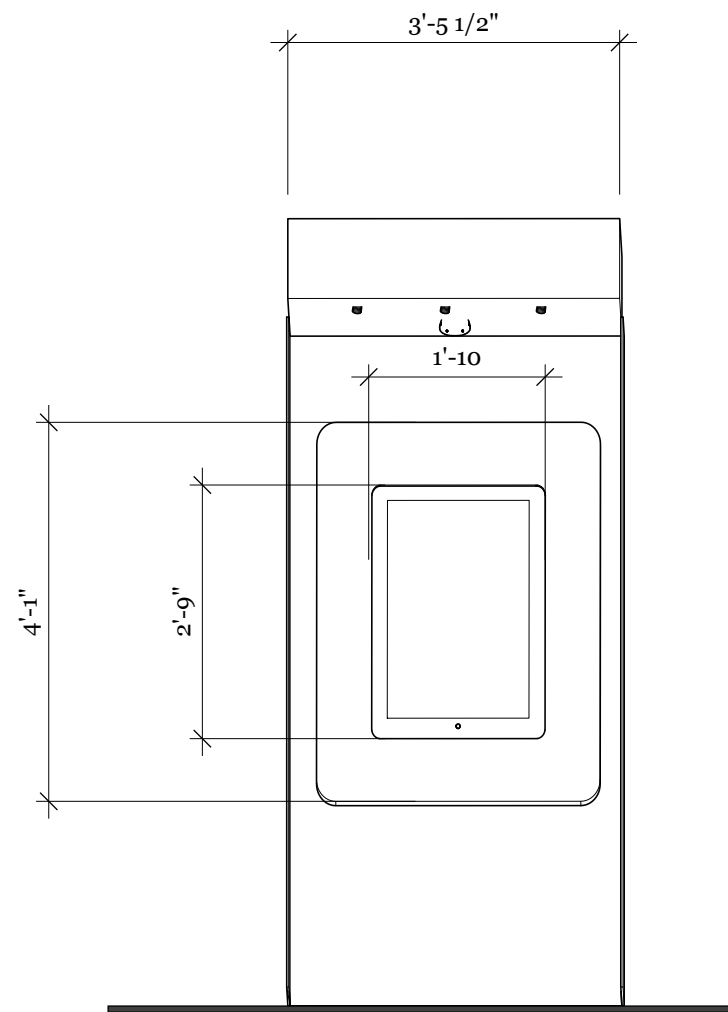

1 :: o2A.o6.GRo1 Elevation Front View "A"
Scale 1/2" = 1'

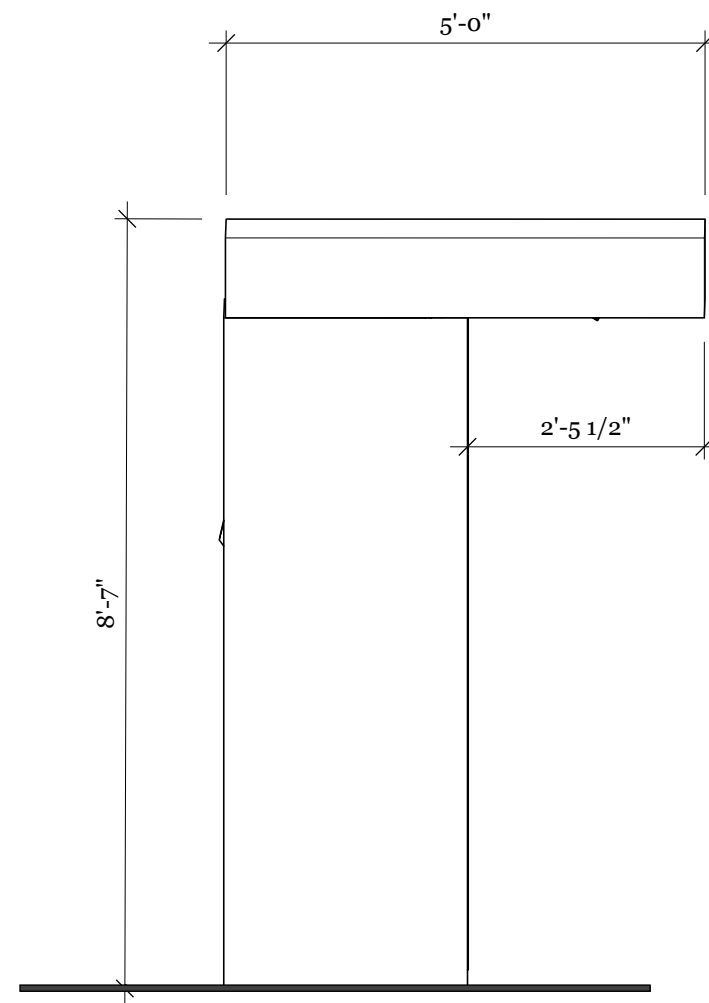

2 :: o2A.o6.GRo1 Elevation Side View "B"
Scale 1/2" = 1'

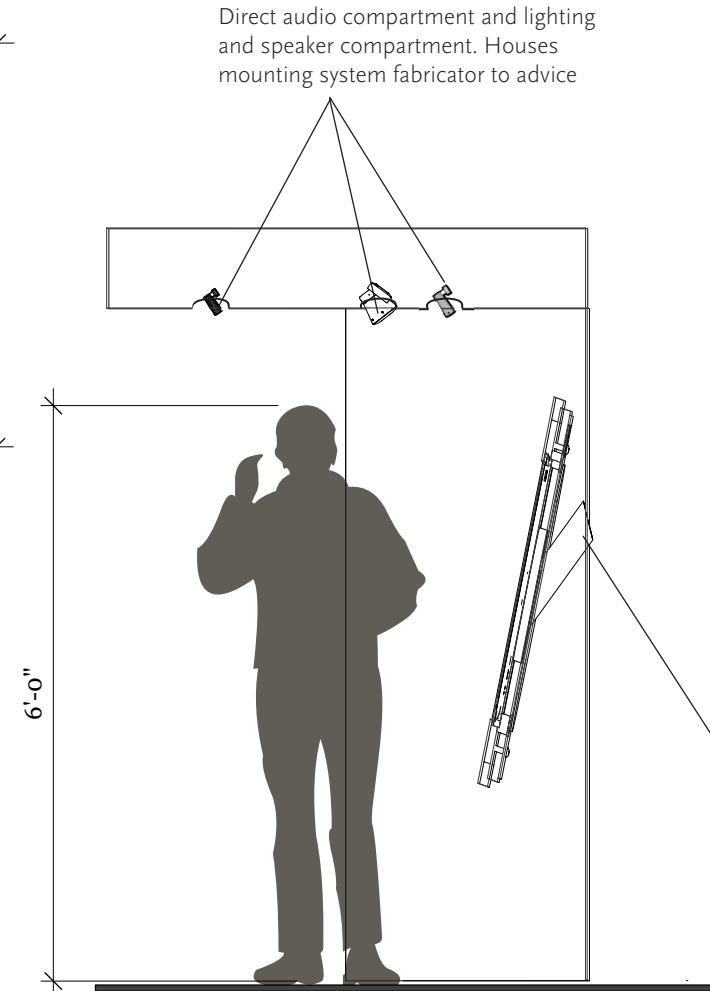

3 :: o2A.o6.GRo1 Elevation Side View XRay
Scale 1/2" = 1'

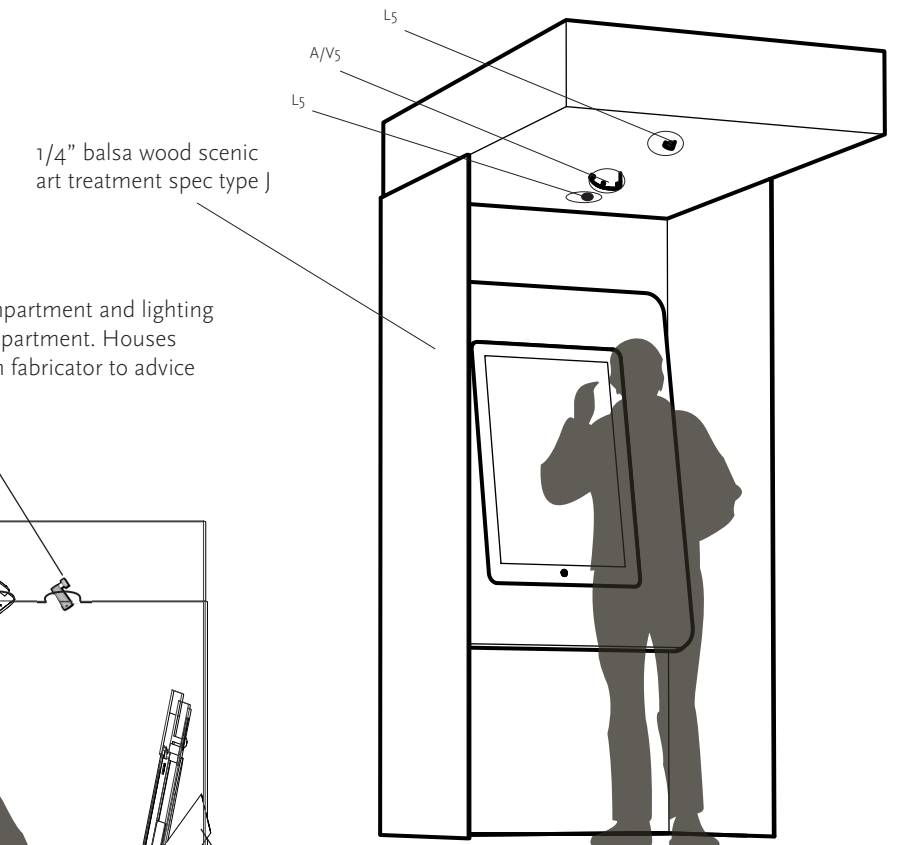

3 :: o2A.o6.GRo1 Perspective Reference
Scale N/A

:: o2A.o6.GRo1 | Enter the Bloodstream

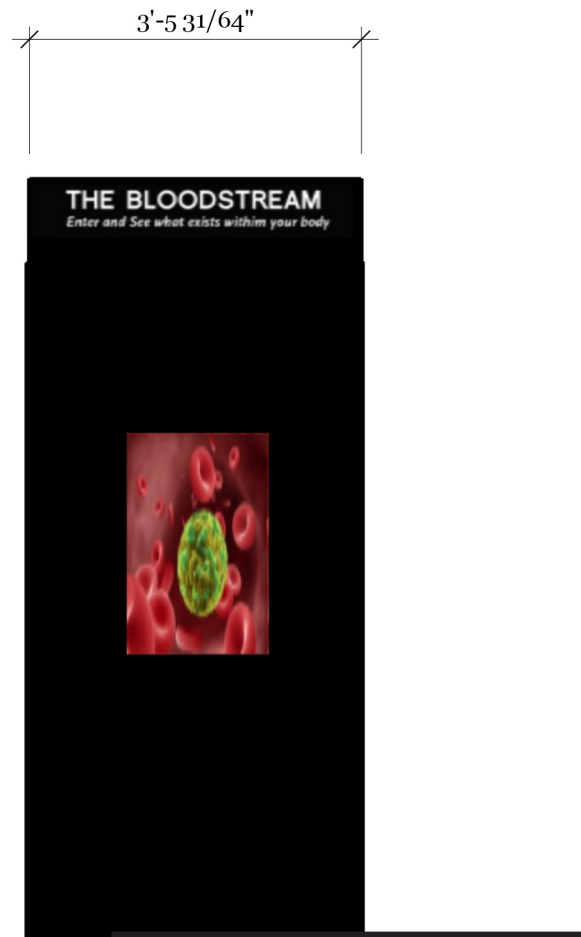

1 :: o2A.o6.GRo1 Elevation Front View "A"
Scale 1/2" = 1'

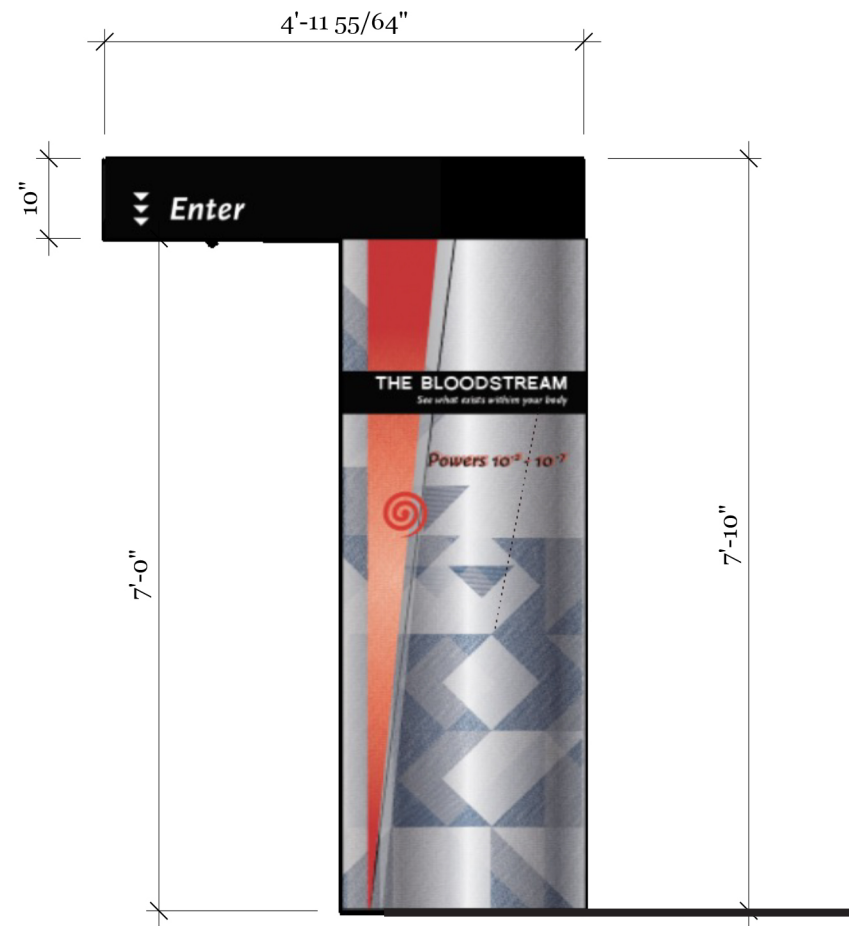

2 :: o2A.o6.GRo1 Elevation Side View "B"
Scale 1/2" = 1'



3 :: o2A.o6.GRo1 Elevation Back View "C"
Scale 1/2" = 1'



Eve Frudakis <i>Exhibition and Experience Design</i>	Fashion Institute of Technology <i>School of Graduate Studies</i> 272 West 27th St. New York, NY 10011	Project: 	Client: 	DISCLAIMER This is an unpublished and proprietary work simultaneously protected under copyright, trade secret, and like laws of the United States and other countries. All rights reserved. These materials may not be reproduced, displayed, distributed, nor may be the information therein be used or disclosed in whole or in part, without the express written permission of Eve Frudakis.	Key Plan: 	Title: A02 <i>Enter the Bloodstream</i>	Scale: 1/2" = 1'		EX 519
	EXHIBITION DOCUMENTATION						Drawn by: <i>Eve Frudakis</i> Date: 11.03.2021		Drawing NO.

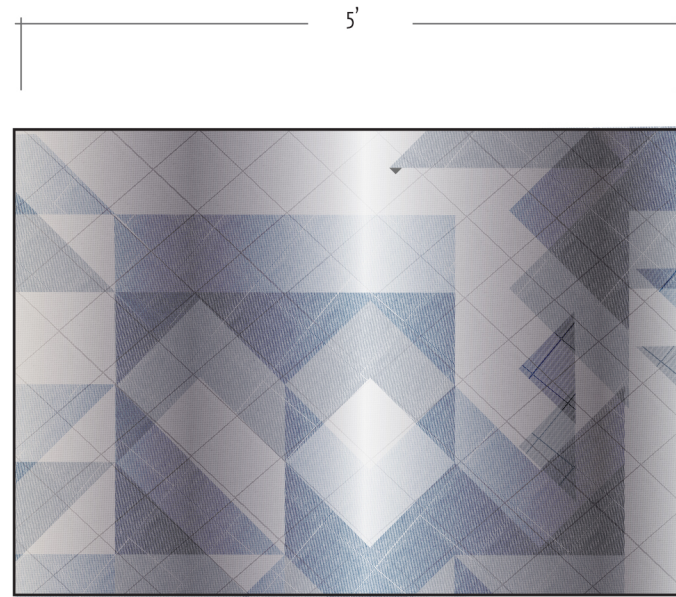

1 :: o2A.o6.GRo1 Top View
Scale 1/2 = 1'



3 :: o2A.o6.GRo1 Front View
Scale 1/2 = 1'



2 :: o2A.o6.GRo1 Top Side View
Scale 1/2 = 1'

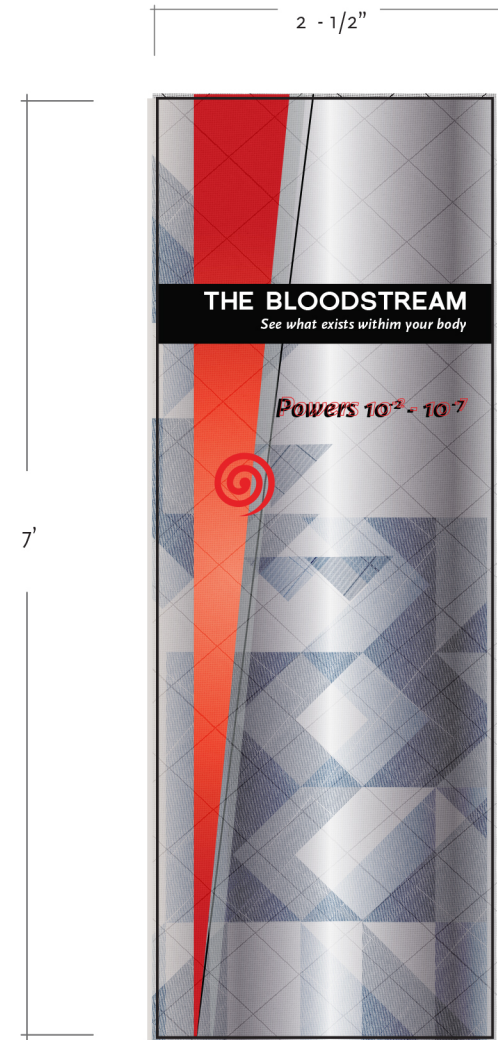

4 :: o2A.o6.GRo1 Side View "B"
Scale 1/2 = 1'



5 :: o2A.o6.GRo1 Back View "C"
Scale 1/2 = 1'



6 :: o2A.o6.GRo1 Perspective eference
Scale 1/2 = 1'

Eve Frudakis Exhibition and Experience Design EXHIBITION DOCUMENTATION	Fashion Institute of Technology School of Graduate Studies 272 West 27th St. New York, NY 10011	Project: CATALYST Made of Stars	Client: AMERICAN MUSEUM & NATURAL HISTORY	DISCLAIMER This is an unpublished and proprietary work simultaneously protected under copyright, trade secret, and like laws of the United States and other countries. All rights reserved. These materials may not be reproduced, displayed, distributed, nor may be the information therein be used or disclosed in whole or in part, without the express written permission of Eve Frudakis.	Key Plan: 	Title: o2A Enter the Bloodstream	Scale: 1/2" = 1' Drawn by: Eve Frudakis Date: 11.03.2021		EX 520 Drawing NO.

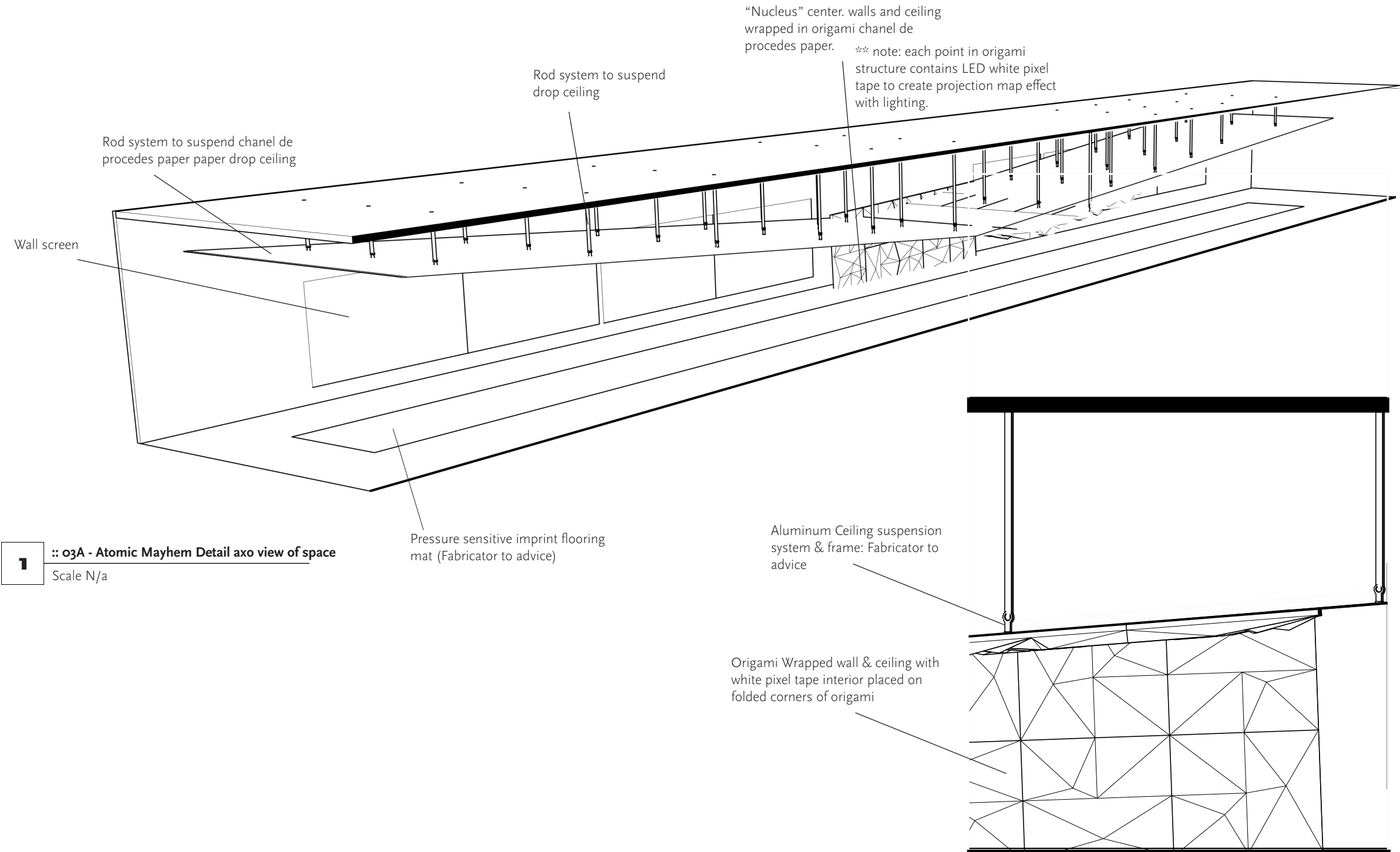

1 :: o3A - Atomic Mayhem Detail axo view of space
Scale N/a

1 :: o3A - Detail
Scale 1/4 = 1'

Eve Frudakis <i>Exhibition and Experience Design</i> EXHIBITION DOCUMENTATION	Fashion Institute of Technology <i>School of Graduate Studies</i> 272 West 27th St. New York, NY 10011	Project: CATALYST <i>Made of Stars</i>	Client: 	DISCLAIMER This is an unpublished and proprietary work simultaneously protected under copyright, trade secret, and like laws of the United States and other countries. All rights reserved. These materials may not be reproduced, displayed, distributed, nor may be the information therein be used or disclosed in whole or in part, without the express written permission of Eve Frudakis.	Key Plan: 	Title: <i>o3A Nucleus Detail</i>	Scale: 1/4 = 1'	EX 521 Drawing NO.
							Drawn by: <i>Eve Frudakis</i> Date: 11.03.2021	